



# DIFFERENTIAL MOVEMENT

## in Platform Timber Frame



**A UKTFA Special Project**

May 2008

## Page of Thanks

A1M Ltd  
A1M Site Services Ltd  
Acacia Timber Construction Ltd  
Actis Insulation Ltd  
Advanced Timber Craft Ltd  
Alexander Timber Design Limited  
Andy Collett Associates  
Anglia Carpentry Contractors Ltd  
Arch Timber Protection  
BEA Fastening Systems Limited  
Bellwood Timber Frame  
Boise Engineering Wood Products Ltd  
British Gypsum - Isover Ltd  
British Gypsum Ltd  
BSW Timber Plc  
Burnham Carpentry Contractors Ltd  
Cameron & Ross  
Canada Wood UK  
Cavalok Building Products Ltd  
CCB Evolution  
CCG (OSM) Ltd  
Christian Torsten Ltd  
Clancy Consulting Ltd  
Clyde Insulation Supplies Ltd  
Covers Timber Structures Ltd  
Crown Timber Plc  
Cullen Building Products Ltd  
Custom Homes  
DBM Consultants  
Deeside Timberframe Ltd  
Donaldson Timber Engineering Ltd  
Douglas Wm Standing  
Drumbow Timber Frame  
ECO Timber Frame Ltd  
Eleco Software Ltd  
Eleco Timber Frame Limited  
English Brothers Limited  
European Timber Systems  
Excel Industries Ltd  
Falcon Panel Products Ltd  
Fawcett Construction  
Finnforest UK Ltd  
Flemings Building Ltd  
Flight Timber Products  
Fforest Timber Engineering Ltd  
Frame Homes UK Ltd  
Frame Wise Ltd  
Gang-Nail Systems Ltd  
Genesis Timber Engineering Ltd  
Gibbs Timber Frame Ltd  
Glenalmond Timber Company Ltd  
Goodwins Timber Frame  
Grampian Construction Limited  
Guildford Timber Frame Ltd  
Harlow Bros Ltd  
Holbrook Timber Frame Limited  
Hunton Fiber (UK) Ltd  
Huntsman (Belgium) BVBA  
Ideal Lifts Ltd  
IJM Timber Frame Ltd  
J Danskin & Co Limited  
James Jones & Sons Ltd  
JJ Smith & Co (Woodworking Machinery)  
K Lue Carpentry Ltd  
Kingspan Insulation Ltd  
Klober Ltd  
Knauf Insulation Ltd  
Laing Homes  
Layton Blackham Insurance Brokers  
Leisureline Joinery  
Lewis Timber Frame Ltd  
M&M Timber Frame  
Maple Timber Frame of Langley Limited  
Marlows Timber Engineering  
Masterframe UK Limited  
Mitek Industries Ltd  
MTE (Leicester) Ltd  
Neatwood Homes Ltd  
New World Timber Frame Ltd  
Norbord Ltd  
Oakworth Homes Limited  
Pace Timber Systems  
Panel Agency (Masonite AB)  
Paslode Duo-fast Limited  
Pavlosvskis Lister  
PGM Carpentry Contractors Limited  
Pinewood Structures Ltd  
Poppers Senco UK Ltd  
Potton Ltd  
PPK Timber Designs  
Prestoplan Ltd  
Protim Solignum  
Puhos Board  
Randek BauTech AB  
Regal Carpentry Contractors Ltd  
Robertson Timberkit  
Rockwool Ltd  
Roe Timber Frame Ltd  
Rowlinson Constructions Limited  
RTC Timber Systems  
Rushmoor Engineering Services Ltd  
Scotframe Timber Engineering Ltd  
Sequoia Joinery Limited  
Seven Oaks Timber Engineering Ltd  
Silvatec Design Limited  
Simpson Strong-Tie  
S.J. Root & Co Ltd  
Solo Timber Frame Ltd  
Southern Timber Frame  
Stanley Bostitch  
Steico Limited  
Stewart Milne Timber Systems Ltd  
Strathclyde Timber Systems Ltd  
Swift Timber Homes Ltd  
Sydenhams Timber Engineering Ltd  
Taylor Lane Timber Frame Ltd  
The A Proctor Group  
The Border Design Centre  
The Design People (UK) Ltd  
Thomas Consulting Civil & Structure Engineers  
Thomas Fleming Homes Ltd  
Thomas Mitchell Homes Ltd  
Timber Frameworks Ltd  
Timberframe Wales Ltd  
Timberlok Limited  
Trade Fabrication Systems Ltd  
Unibud SP zoo (Danwood House)  
Unitek Timber Frame Systems  
UPM Kymmern Wood Ltd  
Walker Timber Ltd  
Wolf Systems Ltd  
Wyckham Blackwell Ltd  
Xella Dry Lining Systems  
Xtratherm UK Ltd  
Young Black Ltd

**Document :**

Guidance on detailing junctions to accommodate differential movement in timber frame buildings

**Forward**

This document has been written by Ian Loughnane, Technical Director, Prestoplan and illustrated by CCB Evolution, timber frame consultants, as part of the UK Timber Frame Association's initiative to promote good practice. The authors wish to thank the UKTFA Technical Committee for their oversight and contribution to the work.

Project funding was provided by the UKTFA special project fund, NHBC and Wood for Good.

This publication is referred to by the NHBC warranty manual and we would particularly like to thank Peter Crane of the NHBC for his encouragement and contribution to the project.

The technical content was agreed by the UKTFA Technical Committee and thanks are given to all companies who have contributed to the document.

---

**Contents**

<b>Ref</b>	<b>Topic</b>	<b>Page</b>
<b>1.0</b>	Understanding the principles	<b>3</b>
<b>2.0</b>	Guidance on timber frame movement	<b>7</b>
<b>2.1</b>	Introduction and key to drawings	<b>7</b>
<b>2.2</b>	Joint Location – Windows	<b>8</b>
<b>2.3</b>	Joint Location – Roofline Eaves and Verge	<b>15</b>
<b>2.4</b>	Joint Location – Non Masonry Cladding	<b>19</b>
<b>2.5</b>	Joint Location – Balconies	<b>23</b>
<b>2.6</b>	Joint Location – Drive Through Details	<b>29</b>
<b>2.7</b>	Joint Location – Stairs & Common Areas with Timber Frame Surround	<b>31</b>
<b>2.8</b>	Joint Location – Concrete and Masonry Stairs / Common Areas with Timber Frame Surround	<b>34</b>
<b>2.9</b>	Joint Location – Lift shafts	<b>37</b>
<b>2.10</b>	Joint Location – Services	<b>40</b>
<b>2.11</b>	Joint Location – Chimneys and Masonry fireplaces	<b>45</b>
<b>2.12</b>	Joint Location – Existing Building Extensions	<b>48</b>

## 1.0 Understanding the Principles

### 1.1 Introduction

Timber frame structures reduce in overall height during the first two years of use. This movement may affect other building elements unless properly constructed to cope with the resulting differential movement. This document provides a comprehensive overview of the locations to be considered based on many years experience.

This publication does not provide joint details or technical fabrication drawings but rather guidance aimed at Architects and Builders to promote a better understanding of the principles to ensure that defects caused by lack of movement joints are avoided.

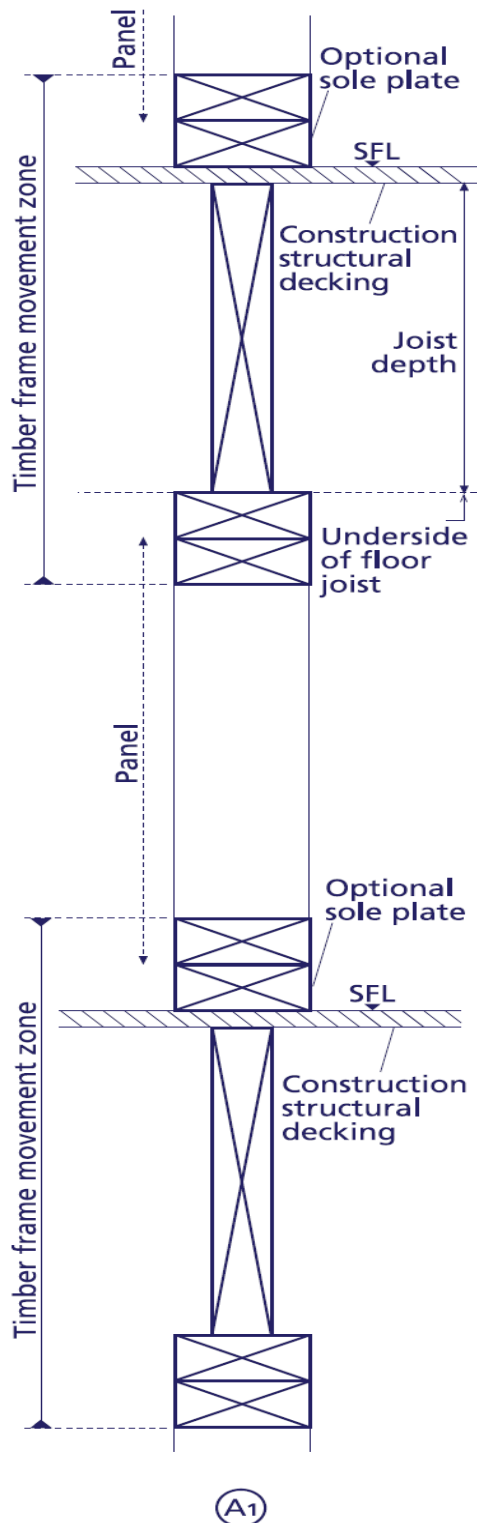
### 1.2 Background

#### 1.2.1 Technical Basics

Timber framed buildings reduce in overall height during the first two years of use. The magnitude of this movement will be calculated by the frame's manufacturer. The following mechanisms, in order of magnitude, drive this characteristic:

- Reduction in the moisture content of the timber cross section (Up to two years after hand over)
- Tightening up of joints under load (which is complete at the end of the construction period)
- Elastic shortening of compression members under load (which is a minor movement)

The diagram below illustrates the mechanism.



The adjacent diagram shows the typical elements that may exist through an upper storey height section.

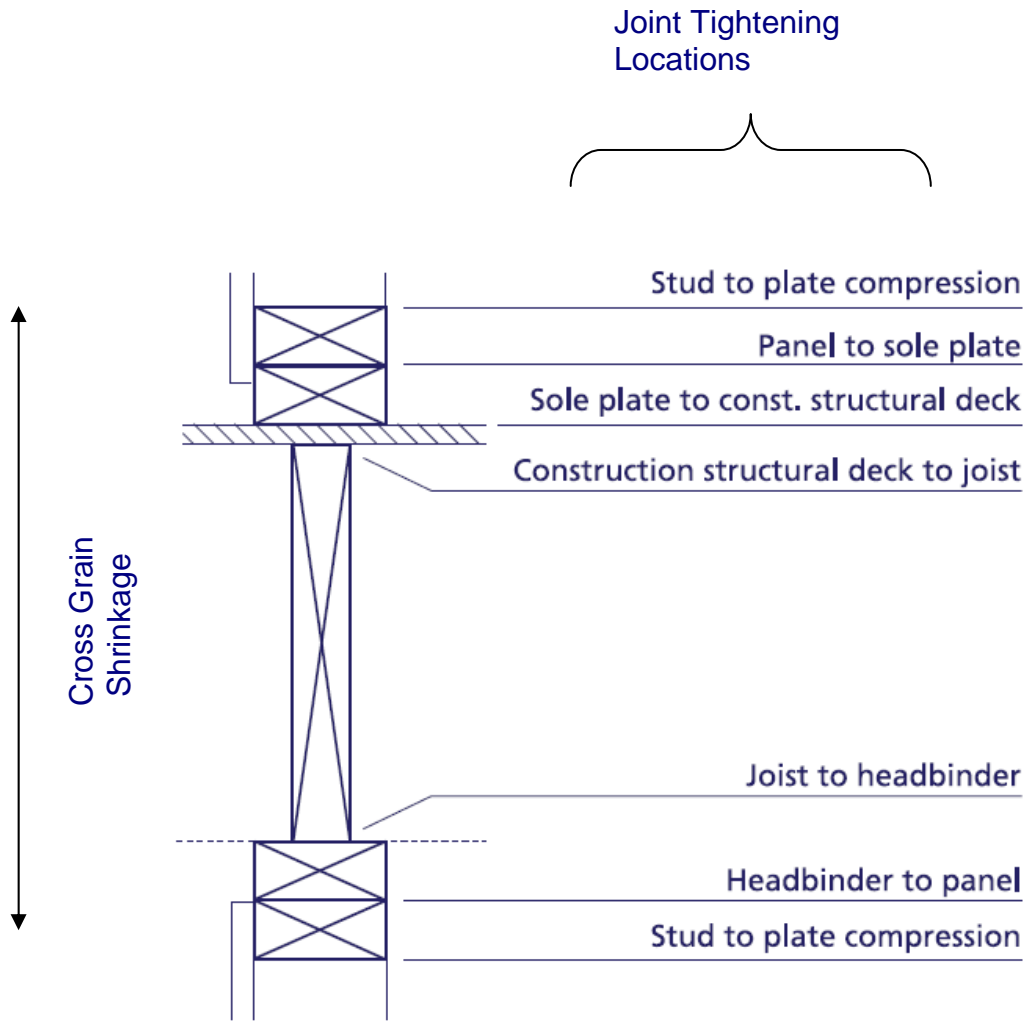
The primary mechanism driving reduction in height is shrinkage of cross grain timber as moisture is driven out in use. From this it can be seen that the majority of movement occurs at the floor zone where the cross grain timber is concentrated. (Note: The vertical shortening down the length of timber in studs is negligible.)

– refer to diagram 1.2.2.

By the same token the secondary mechanism of joint tightening also occurs in the same region.

Manufacturers can modify the degree of movement experienced by removing cross grain timber from the frame and utilising timbers of reduced initial moisture content.

Builders can reduce the degree of settlement by tiling the roof or loading out floors before commencing external claddings.



**Diagram 1.2.2 – detail A2 – Cross Grain Shrinkage and junction interfaces where movement can take place**

## UKTFA - Differential Movement Guidance

In the absence of specific data, the movement values for timber frame should be calculated using the following values in the table below:

Cross Sectional Frame material	Movement allowance
20 % moisture content timber – standard timber	2.8 %
14 % moisture content timber – super dry timber and Glulam	1.2 %
10 % engineered wood products (e.g. laminated veneer lumber)	0.6%
NOTE 1 The depth of cross grain timber used in the above calculation should include all soleplates, rails, joist, and plates.	
NOTE 2 Average moisture contents at the time of erection	
NOTE 3 The designer's attention is brought to the possible increased shortening caused by concentrated loads due to compression at junctions and elastic shortening	

### 1.2.2 External Elevations

The timber frame shrinkage occurs throughout the structure but it is typically differential movement to external cladding that requires specific attention in detailing.

The behaviour of the cladding has also to be considered as this can increase the degree of movement experienced by the joint. For example, Steel sheet claddings expand and contract with temperature, clay masonry expands.

The anticipated movement of cladding is to be added to the timber frame values for an overall joint movement figure. It is also common practice for movement joints to be sealed and because sealants cannot compress to zero the final constructed joint depth should be calculated as follows:



**Joint Size = Frame shrinkage + Cladding expansion + Minimum compressed sealant depth**

Joint sizes and positions will vary dependent on height of the frame and whether or not the cladding (internal or external) is fixed or independent of the structure.

## 2.0 Timber Frame Movement Guidance

### 2.1 Introduction and Key to drawings

The following sections and drawings provide guidance on principles for construction detailing. Each section provides a topic with drawings illustrating the direction of movement. The drawings show the difference in levels from the time of build (referred to as “before”) to final level (referred to as “after”).

<b>Key to Drawing Symbols</b>	
	Downward timber frame movement. Direction shown by the arrow.
	Brick / cladding expansion – shown by the arrow as upward movement.
<b>C.G.</b>	Initial Construction Gap – “before”
<b>F.G.</b>	Final Gap – post-movement – “after”
<b>O.G.</b>	Opened Gap – post-movement – “after”

## **2.2 Joint Location – Windows**

Windows are fixed to the timber frame and sit either within or just behind the external cladding. If the external cladding is supported independently of the timber frame, the vertical movement between the two components (window fixed to the timber frame and cladding) needs to be considered. A movement joint will be required on all four sides of an opening. Where the cladding is supported by the timber frame there is no differential vertical movement to consider other than any expansion or contraction of the cladding system.

There are two common locations for windows or other similar units such as, doors to balconies.

In Scotland it is common to fix the window directly behind the masonry with an extended cill. The masonry reveals lap over the frame at the sides and the top leaving a physical joint gap at the base only.

Elsewhere the window is pushed forward to sit within the masonry skin. In this instance movement joints need to be provided on all four sides.

Special consideration needs to be given to full height glazing commonly seen on stair wells. The window frame must allow for the shortening of the building without becoming loaded. Often this is achieved by splitting the glazing into storey height units with a movement joint at each floor level.

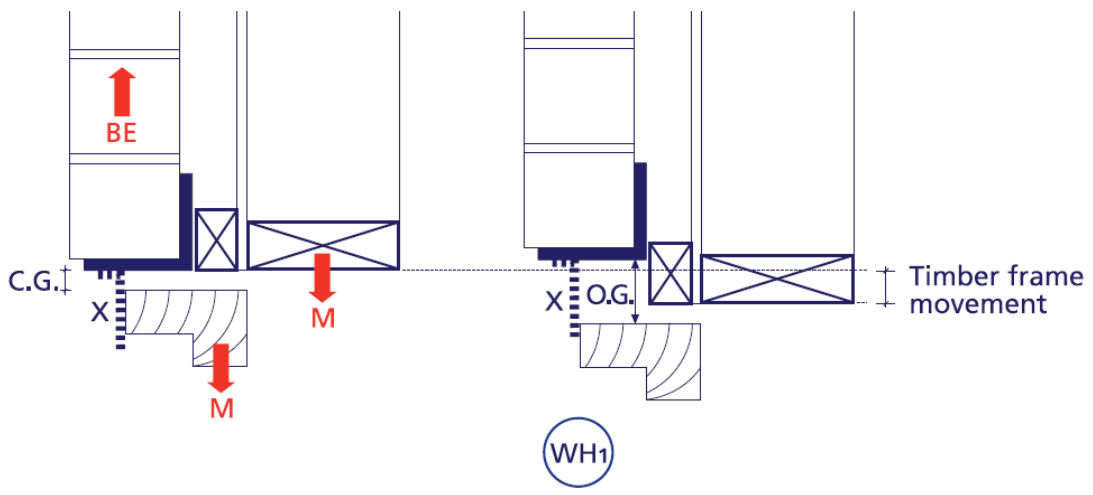
### **Avoiding Problems**

1. Use a sealing system that can cope with the movement<sup>1</sup>.
2. Ensure the joint is not compromised for example by mortar intrusion
3. Ensure window packing shims do not extend into the joint
4. Ensure that the joint is constructed to the right size.
5. Ensure that sufficient clearance is left on lintel clips<sup>2</sup>.
6. When laying masonry cladding it is essential to take account of soleplate packing as this impacts on the distance from the splash course to the ground floor window and door head positions.

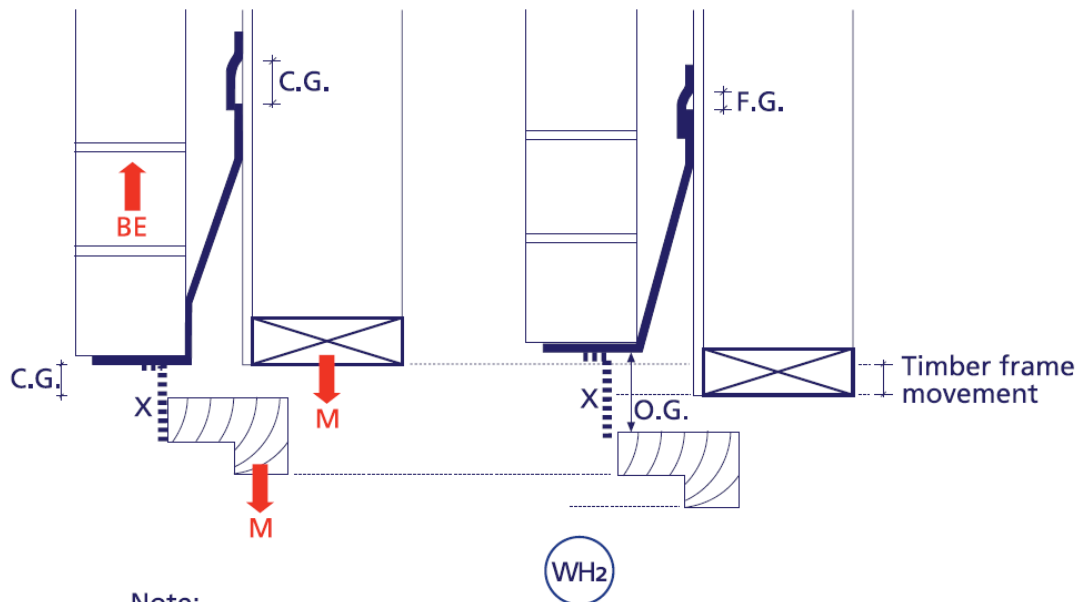
---

<sup>1</sup>**Note** the UKTFA does not recommend the use of silicone sealants in this situation

<sup>2</sup> **Note** the limitations of clipped lintels to take movement - Masonry support lintels utilising clip restraints fixed to the frame are only suitable for low movement as the clearance gap between the clip and lintel closes up as movement takes place.



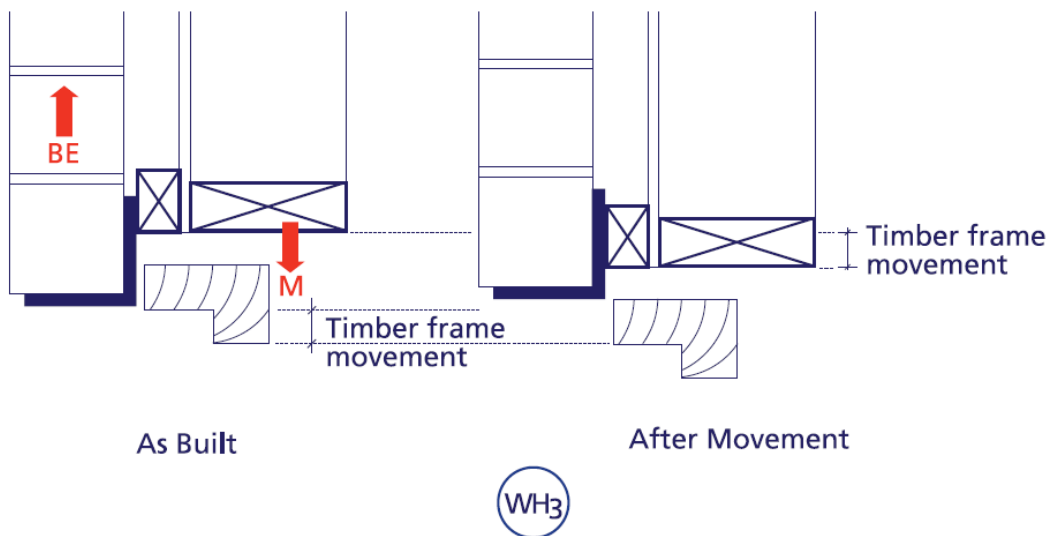
**Diagram 2.2.a- WH1**  
**Window Head junction with masonry cladding**  
**showing before and after vertical movement.**



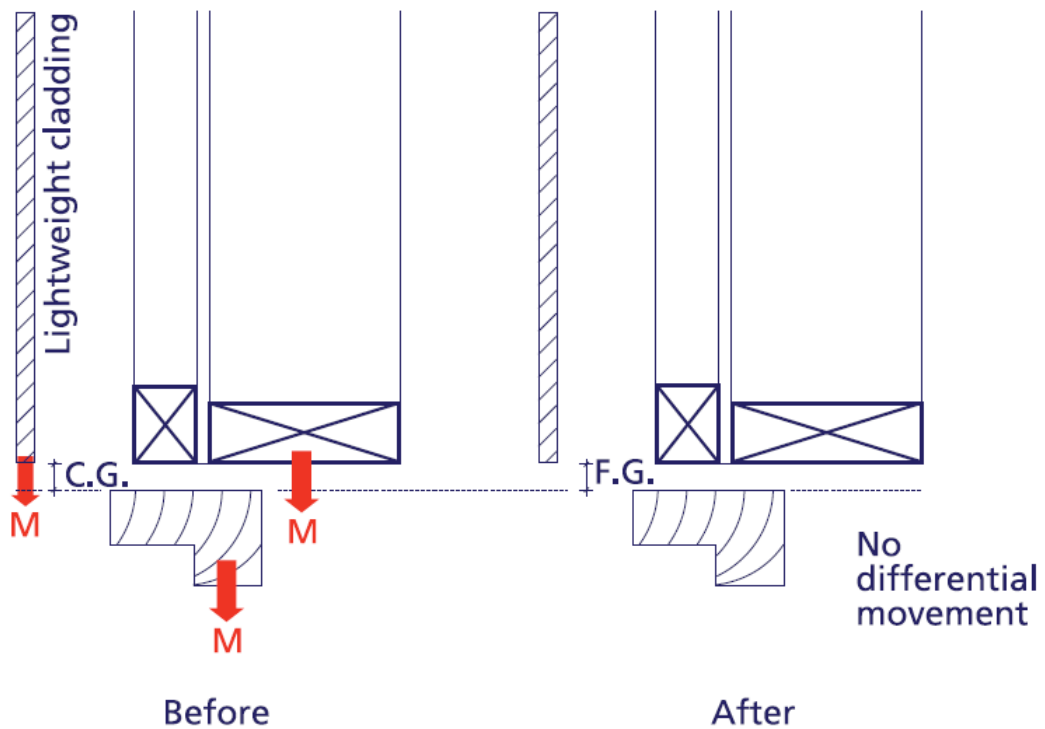
Note:  
Clipped lintels are only suitable for upto three storeys of timber frame

**Diagram 2.2.b- WH2**  
**Window Head junction with masonry cladding and propriety clipped lintel showing before and after vertical movement.**

Note: Clipped lintels are only suitable up to 3 storey timber frame

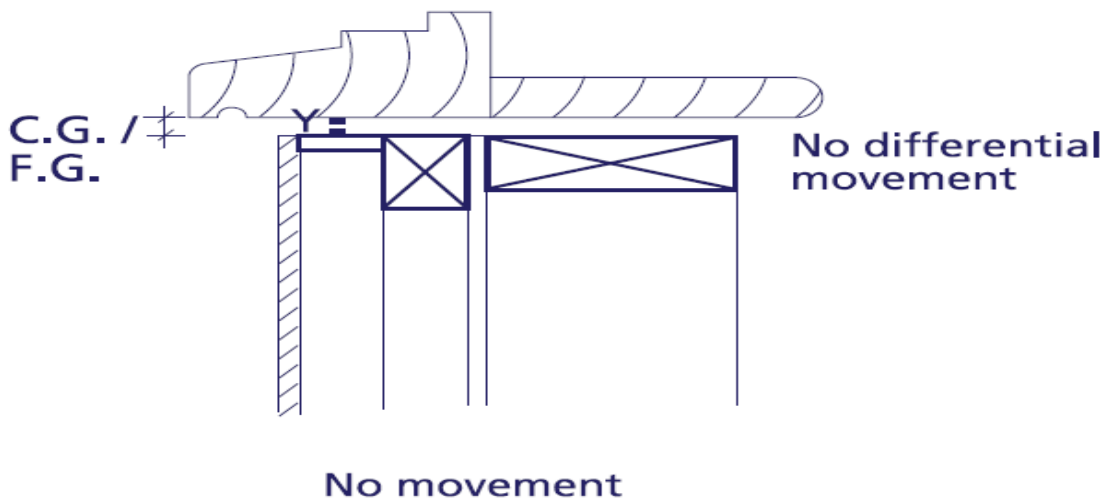


**Diagram 2.2.c- WH3**  
**Window Head junction with masonry cladding and steel angle masonry lintel showing before and after vertical movement.**



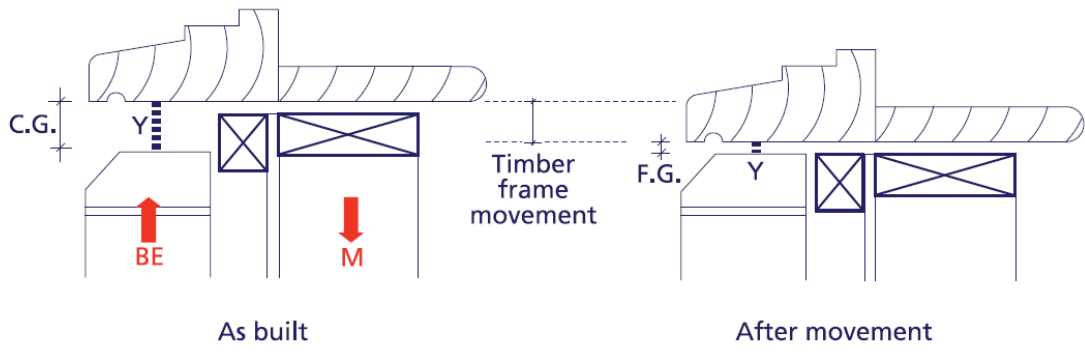
WH4

**Diagram 2.2.d – WH4**  
**Window head junction with – lightweight cladding fixed to the timber frame.**  
**Showing no differential vertical movement before or after.**



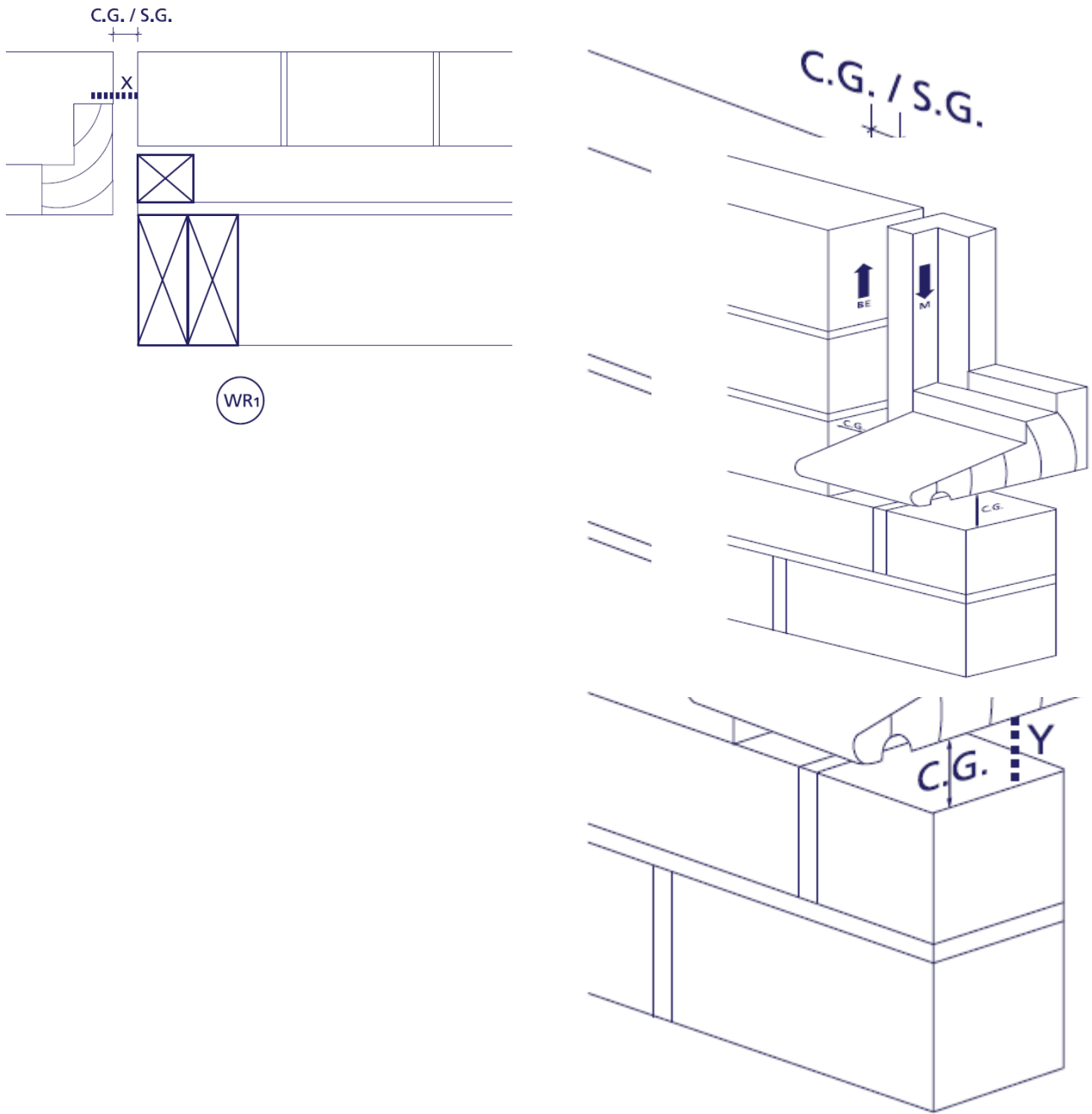
WS1

**Diagram 2.2.e Ws1**  
**Window cill level junction with lightweight cladding and no differential movement**



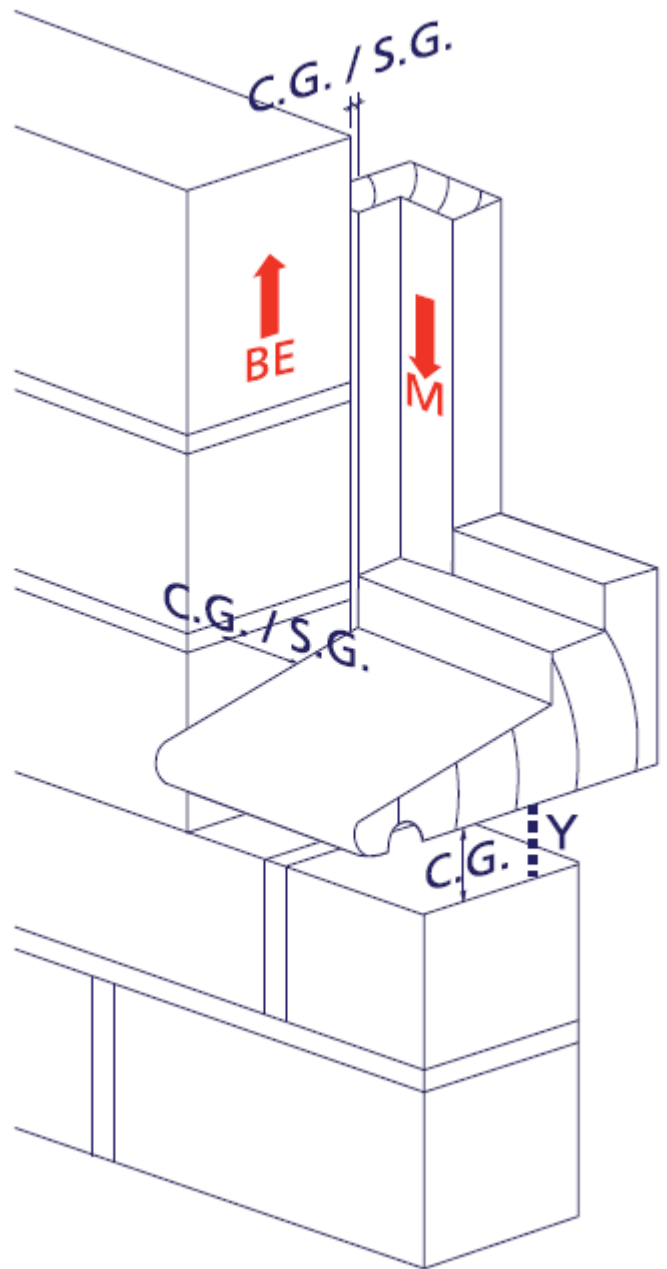
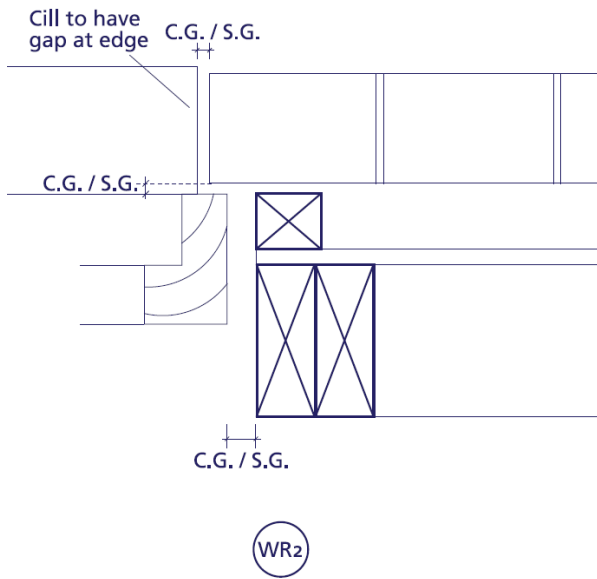
**Diagram 2.2.f Ws2**  
**Window cill level junction with masonry cladding before and after**

**UKTFA - Differential Movement Guidance**



**Diagram 2.2.g-WR1**  
**Plan and elevation**  
**Window Reveal extended into the depth of the masonry cladding**

**UKTFA - Differential Movement Guidance**



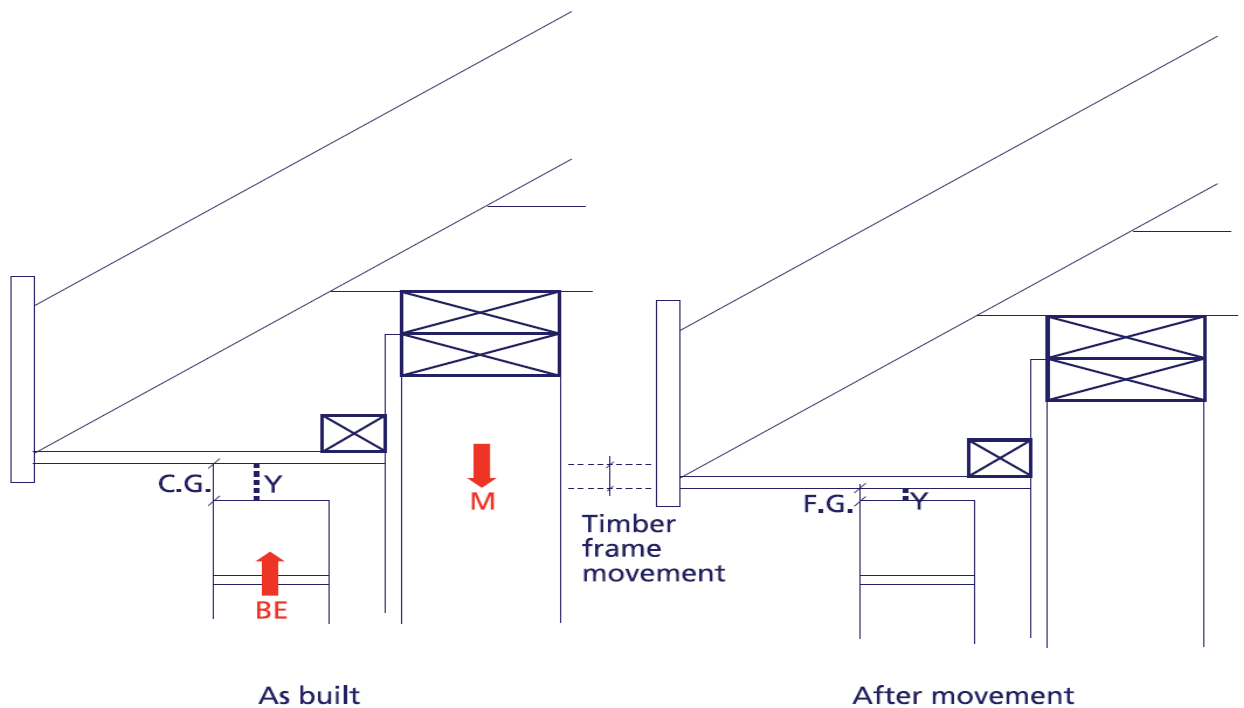
**Diagram 2.2.h- WR2**  
**Plan and elevation**  
**Window Reveal extended into the depth of the masonry cladding**

### **2.3 Joint Location – Roofline Eaves and Verge**

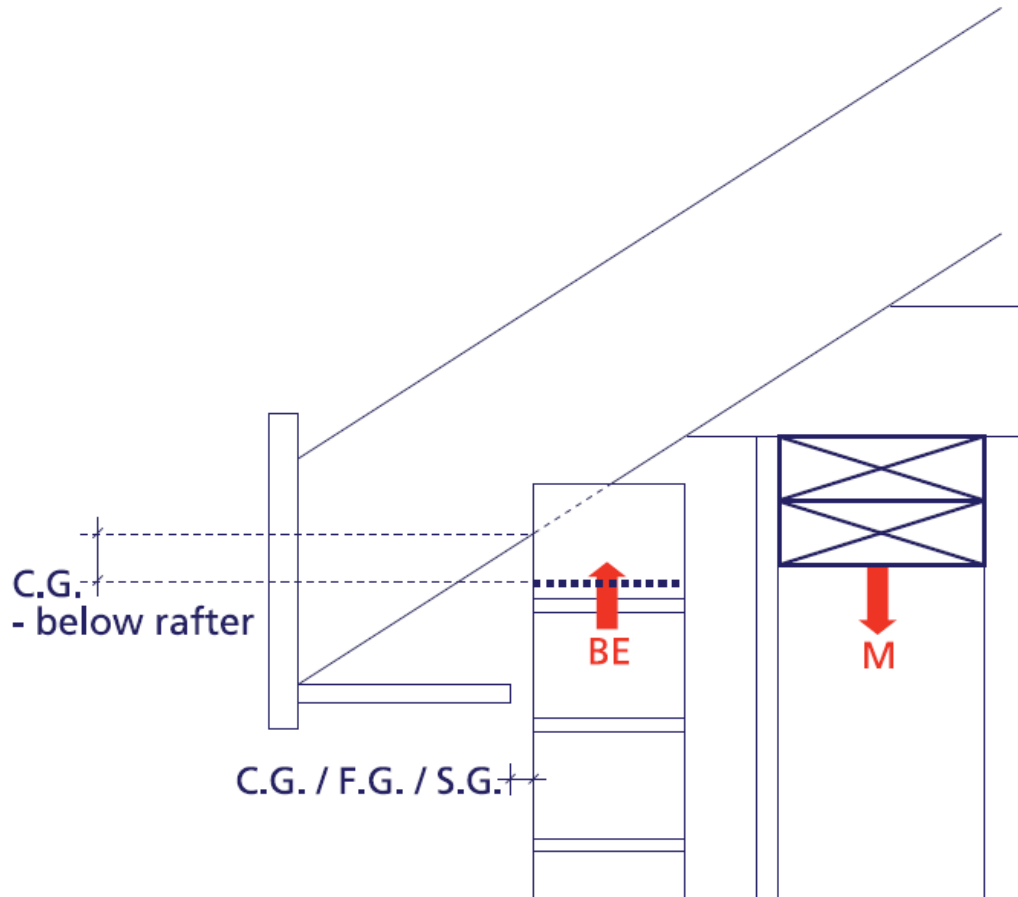
Where roofs are supported by the timber frame they move down with the frame movement. It is therefore essential that perimeter details, typically at the junction with external masonry cladding, allow this movement to occur without damaging the finishes.

#### **Avoiding Problems**

1. Keep masonry below the soffits by the required joint depth
2. Keep masonry below exposed rafters in open eaves detail by the required joint depth
3. Ensure eaves and verge support framework does not bind on masonry



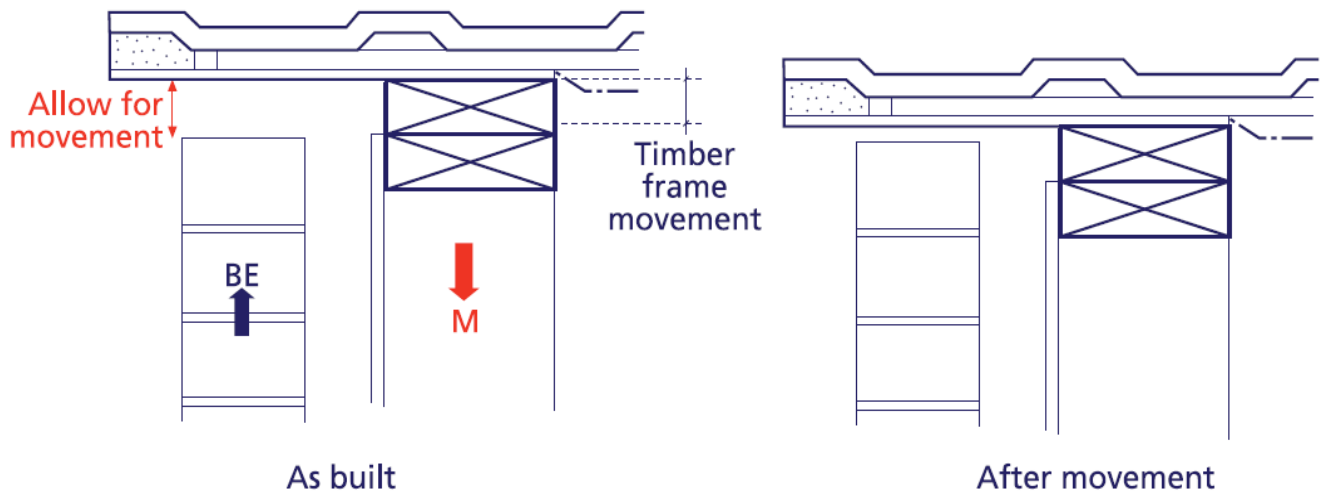
**Diagram 2.3.a**  
**Roof eaves junction with masonry cladding**  
**showing differential movement before and after.**



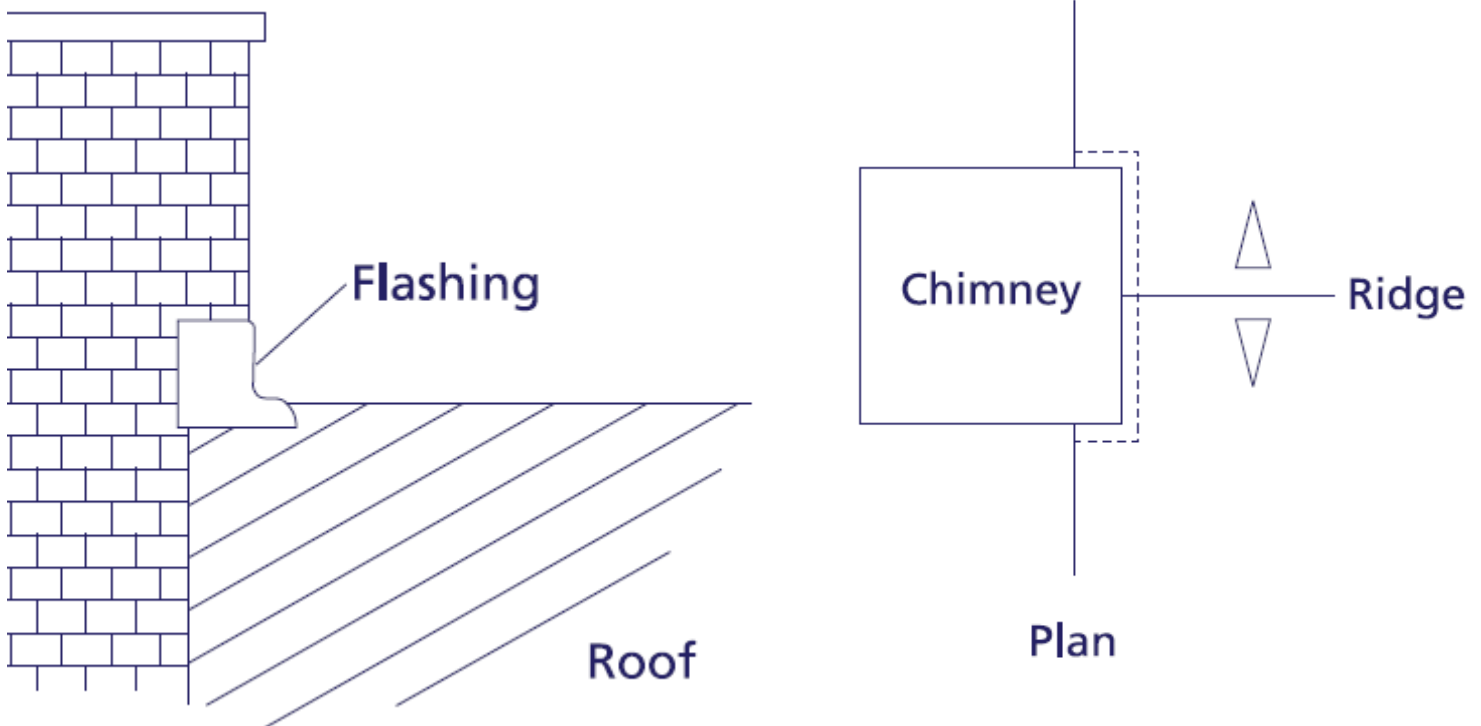
Option for eaves R1

(R1)

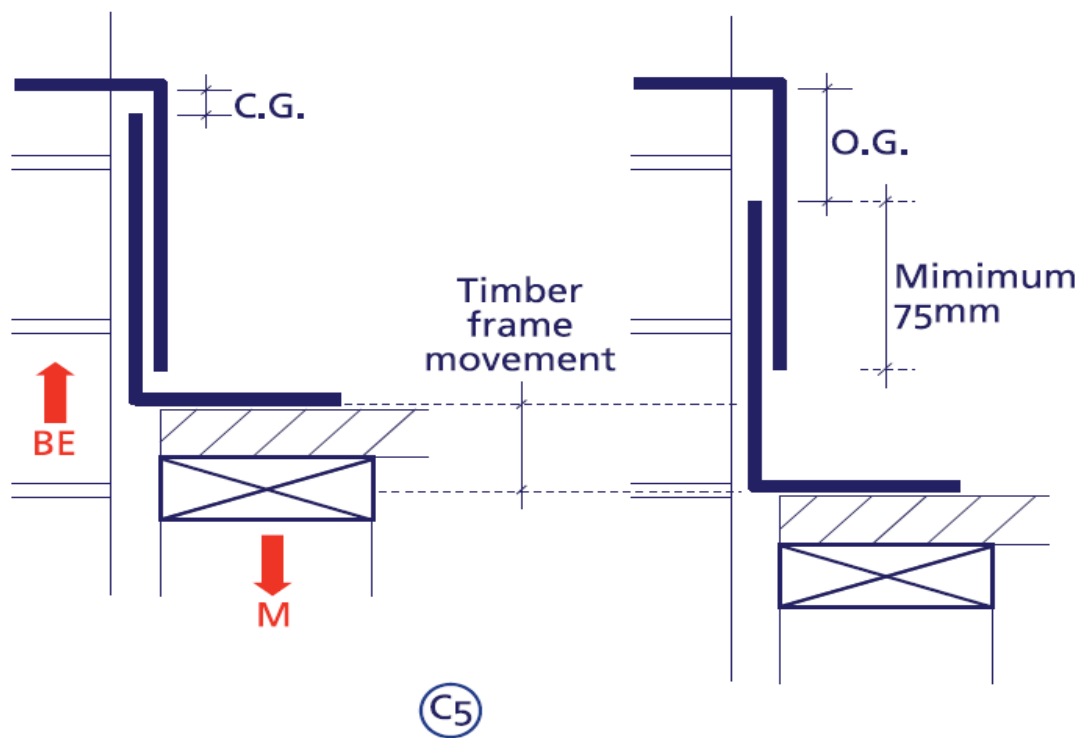
**Diagram 2.3.b**  
**Alternative roof eaves junction with masonry cladding**  
**showing differential movement directions.**



**Diagram 2.3.c**  
**Verge junction with masonry cladding**  
**showing differential movement before and after.**



**Diagram 2.3.d**  
**Verge detail with masonry chimney interface**



**Diagram 2.3.e – refer to 2.3.d for location example**  
**Verge detail with masonry chimney showing options for flashing**  
**Note this guidance is for where a chimney is fully supported by masonry.**

## **2.4 Joint Location – Non Masonry Cladding**

Where cladding is supported directly by the frame<sup>3</sup> the majority of movement occurs at the floor zone. Joint sizing is therefore independent of the frame height and only the movement at each floor zone needs to be accommodated.

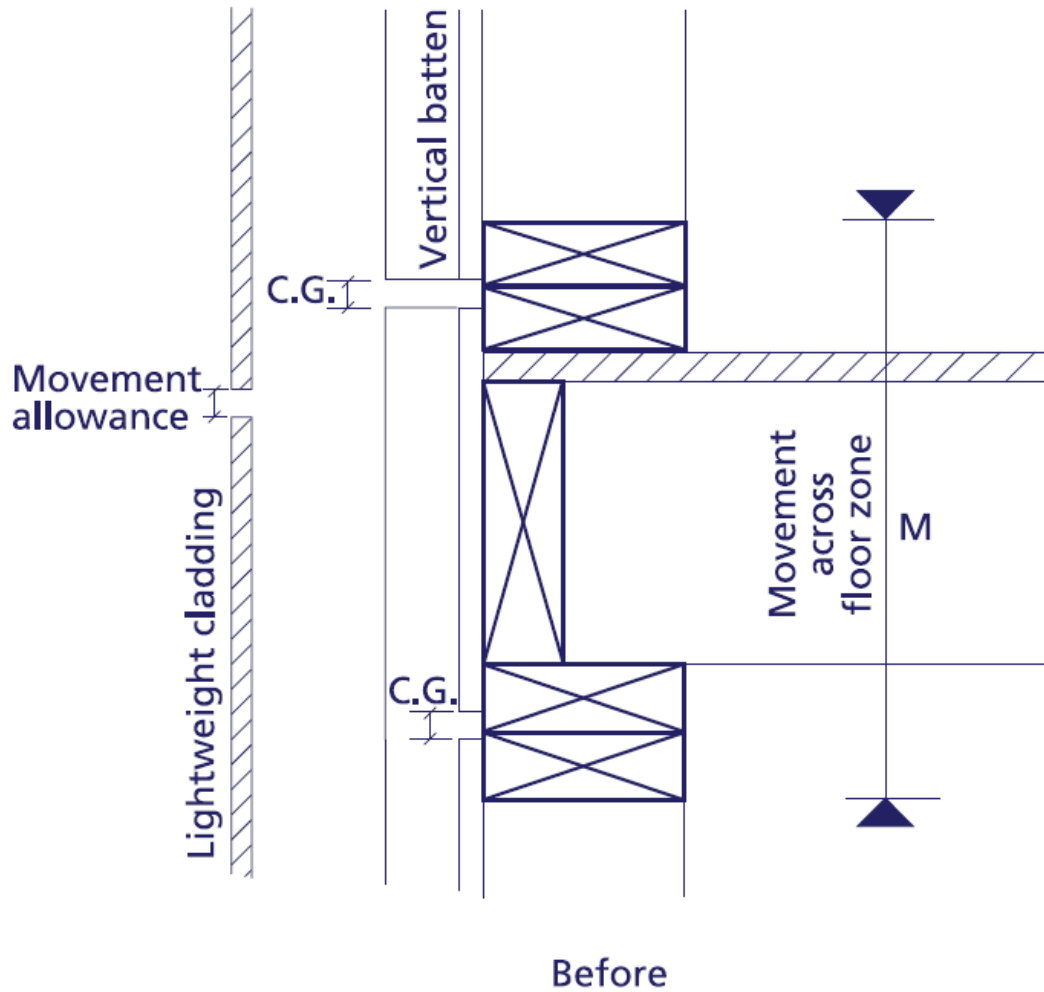
Each joint is the same size and located at the floor zone. When forming these joints it is essential to consider the implications for fire barriers and cavity ventilation.

### **Avoiding Problems**

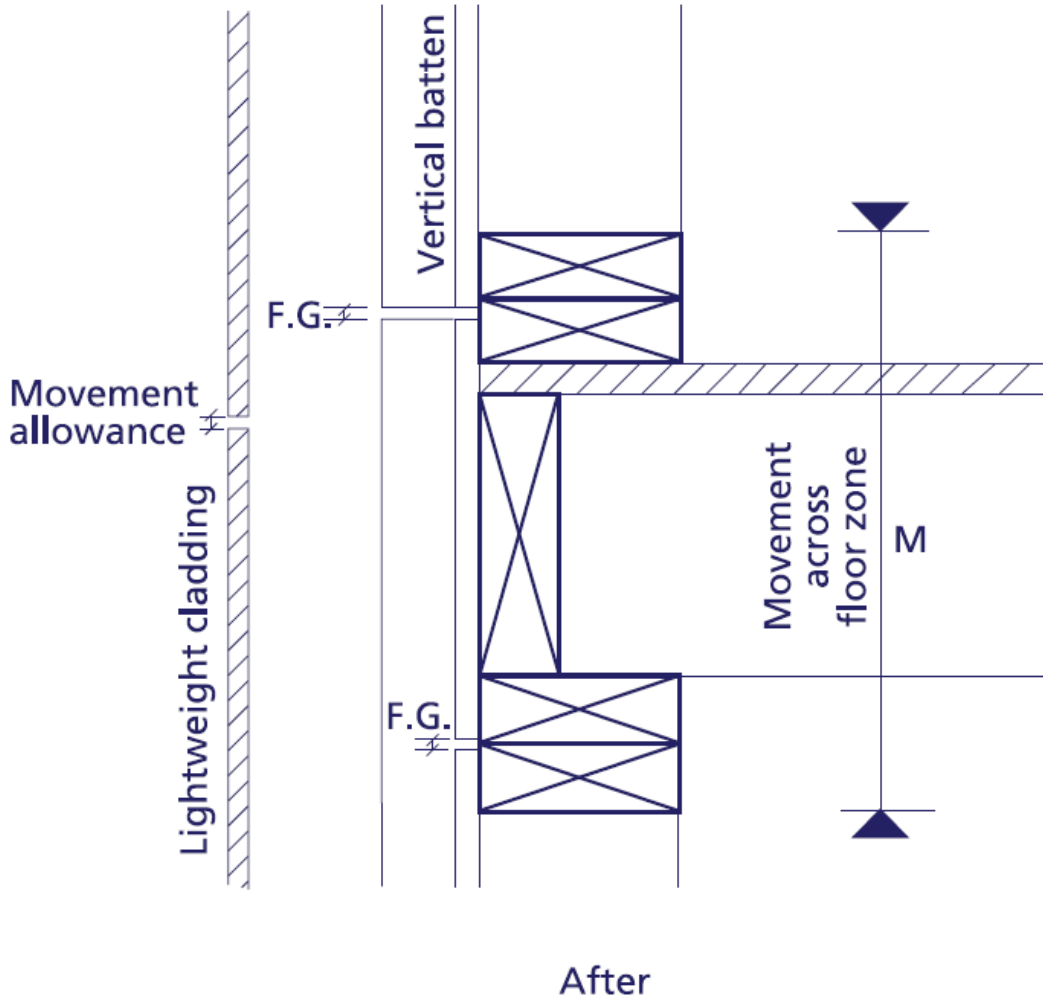
1. Ensure that the movement joint detailing includes the cladding support framing so that all elements of the cladding system can accommodate movement
2. Use a sealing system that can cope with the movement

---

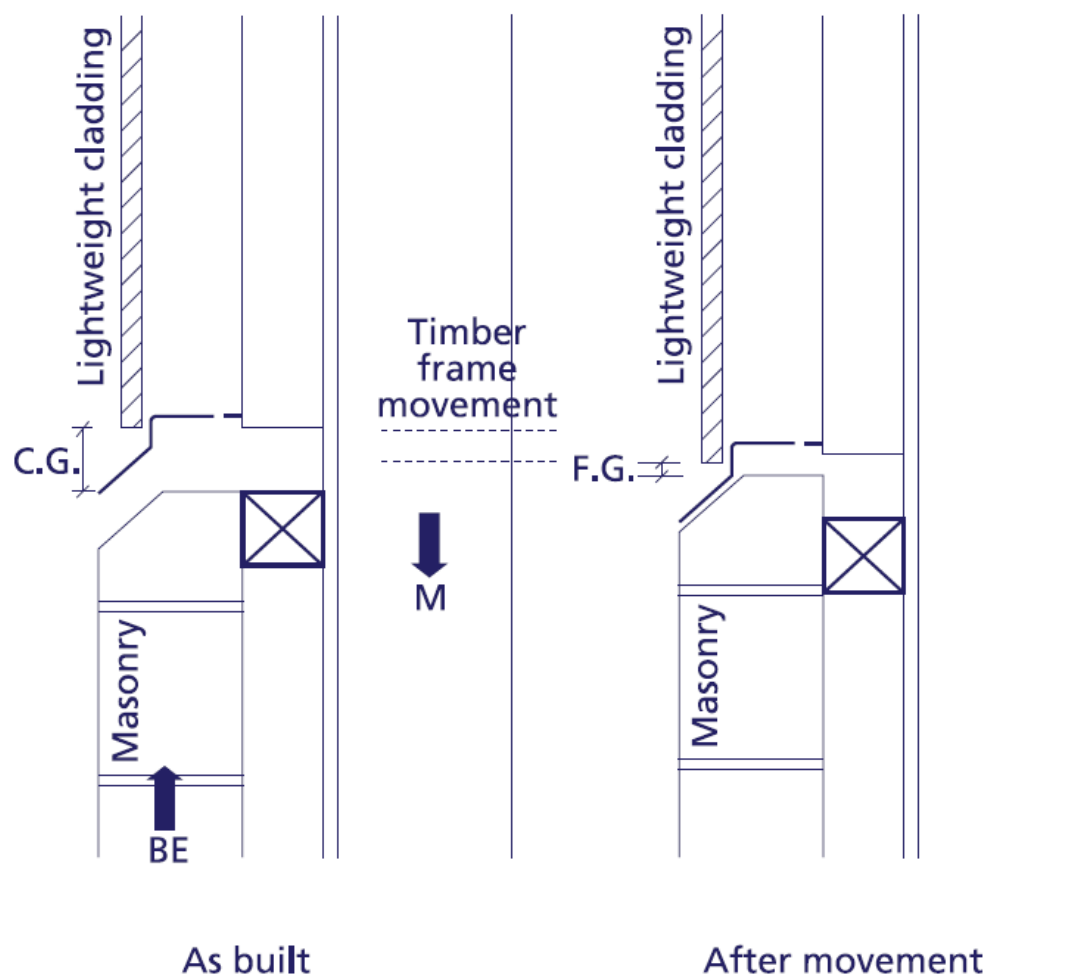
<sup>3</sup> Even if there is a cavity between the cladding and the frame this is still the case.



**Diagram 2.4.a**  
**Junction at the floor zone with lightweight cladding supported by timber frame as built**



**Diagram 2.4.b**  
**Junction at the floor zone with lightweight cladding supported by timber frame.**  
**after movement**



C2

**Diagram 2.4.c – C2**  
***Junction of lightweight cladding to masonry lower wall.***  
***Showing movement between the as built and after movement.***

## **2.5 Joint Location – Balconies**

The requirement for movement joints will be determined by the support arrangement for the balcony. Balconies are often independently supported but tied back to the floor zone of the frame to provide lateral stability.

Inevitably these lateral fixings pass through the cladding zone and will move down with the frame. Movement joints are required below the ties to allow this to occur without unduly loading the connection.

It should also be noted that the detailing of the connection itself should allow for differential movement / rotation. This often requires a pinned joint or slotted hole arrangement. Without such consideration excessive joint loading may lead to damage.

Where balconies are both restrained laterally and vertically supported on the building side there will be some rotation of the balcony floor as the building shortens. This effect can be offset by presetting the balconies to allow for the anticipated shrinkage. It is not unusual to “split the difference” and initially set the balcony out of level to allow for 50% of the calculated frame shrinkage. This allows for the possibility that the frame will not shrink as much as predicted whilst minimising the in built fall<sup>4</sup>.

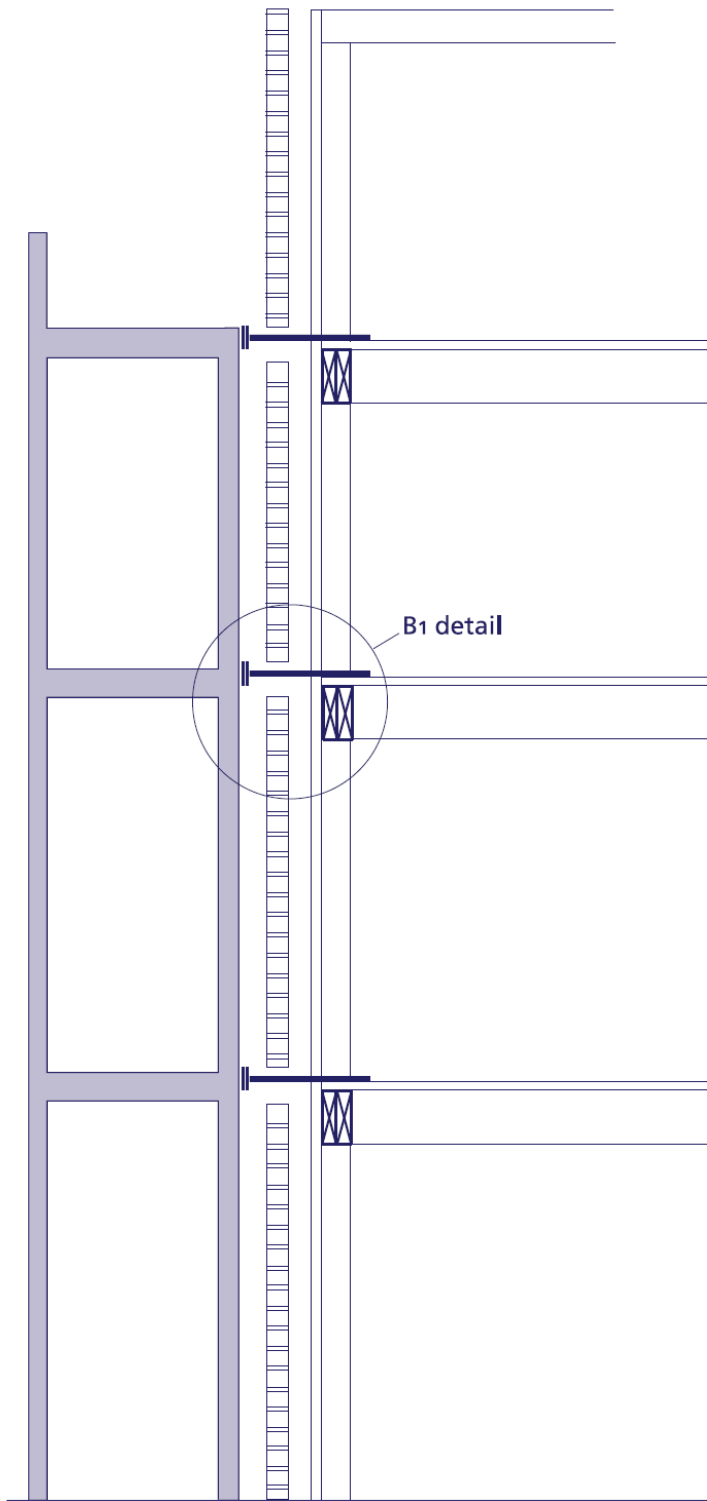
For independently supported balconies the difference in level between the threshold and balcony level will vary as the movement occurs. Flashings and other associated details should take account of this.

### **Avoiding Problems**

1. Ensure that connection design allows any required movement
2. Ensure joints are constructed to the correct size
3. Ensure any designed in falls are constructed accurately

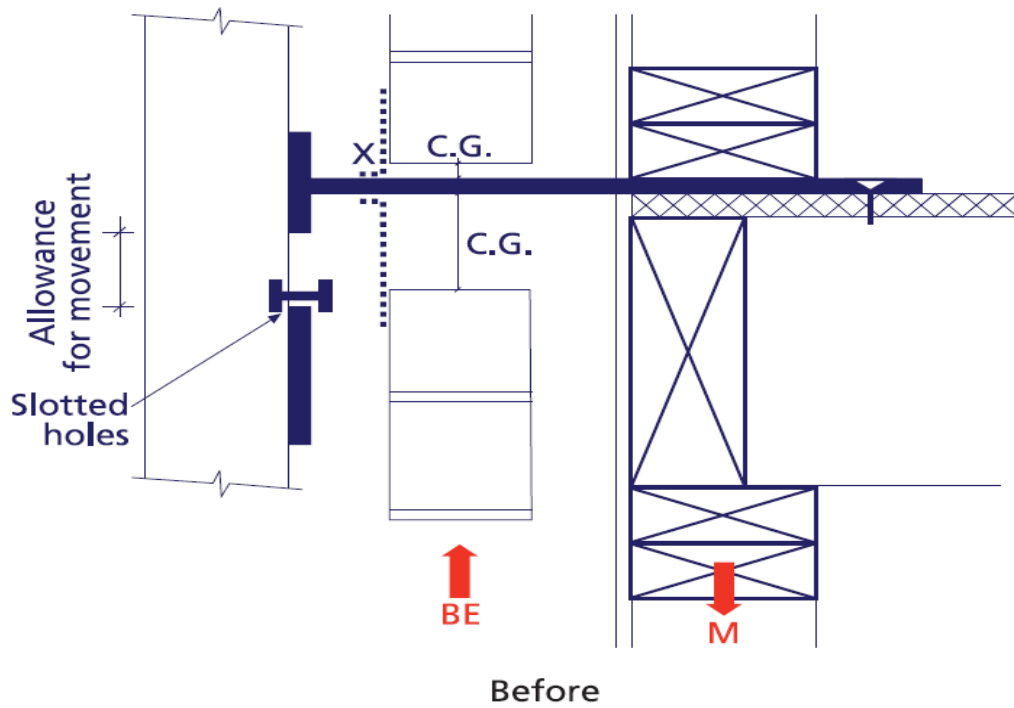
---

<sup>4</sup> Full consideration should be given to the effect of any slopes on the drainage of the balcony

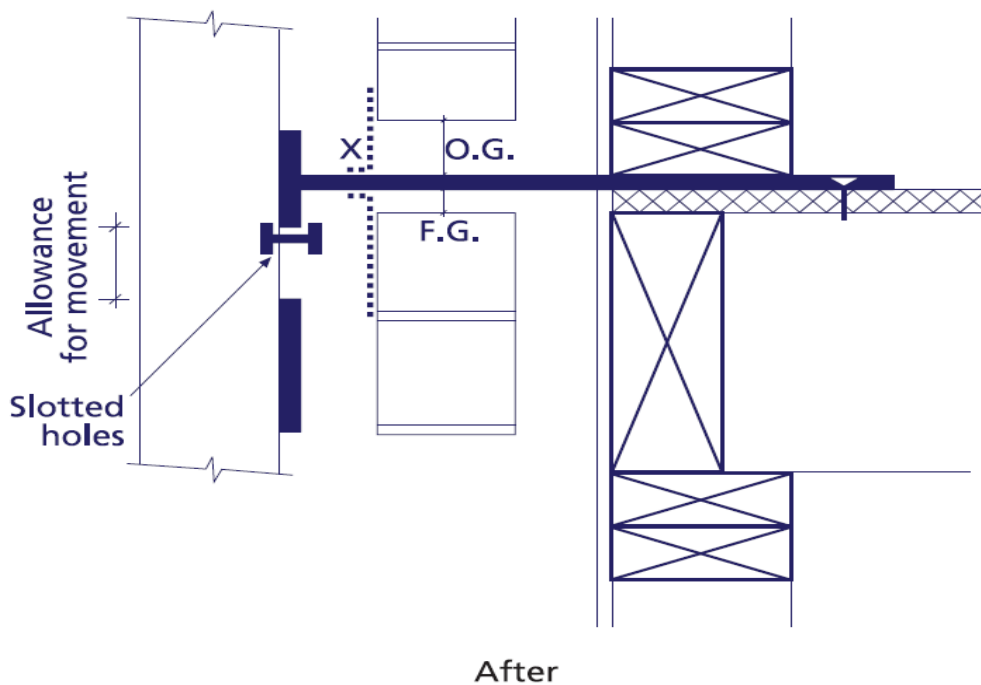


B1

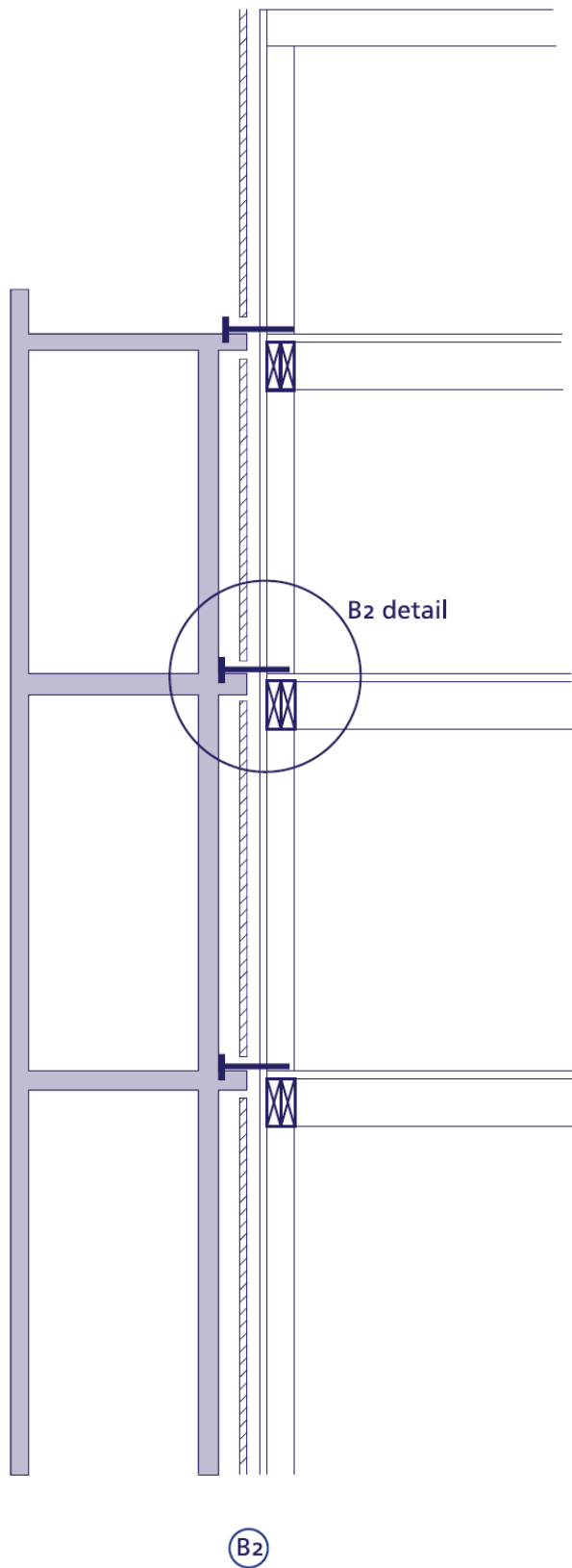
**Diagram 2.5.a –B1**  
**Vertically free standing balcony and masonry**  
**tied back to the timber frame for lateral support**



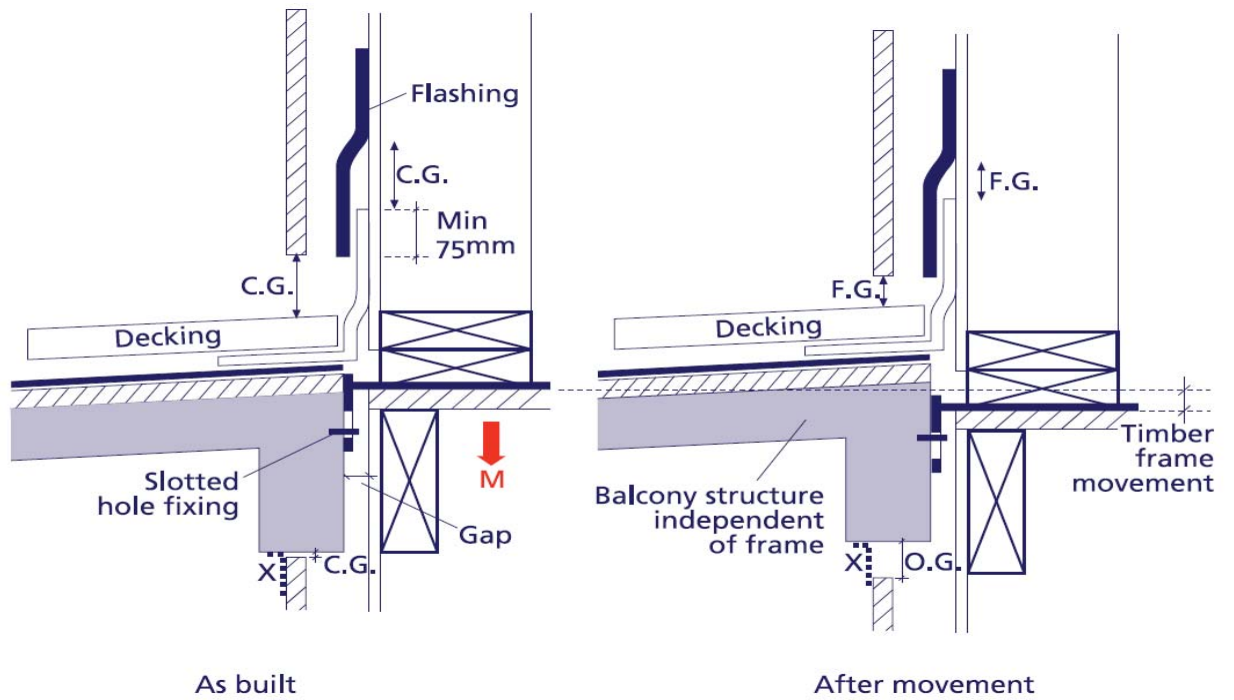
**Diagram 2.5.b – B1 detail**  
**Detail of lateral tie to timber frame**  
**showing movement directions between the frame and masonry**  
**with balcony drawn as the “before” movement stage.**



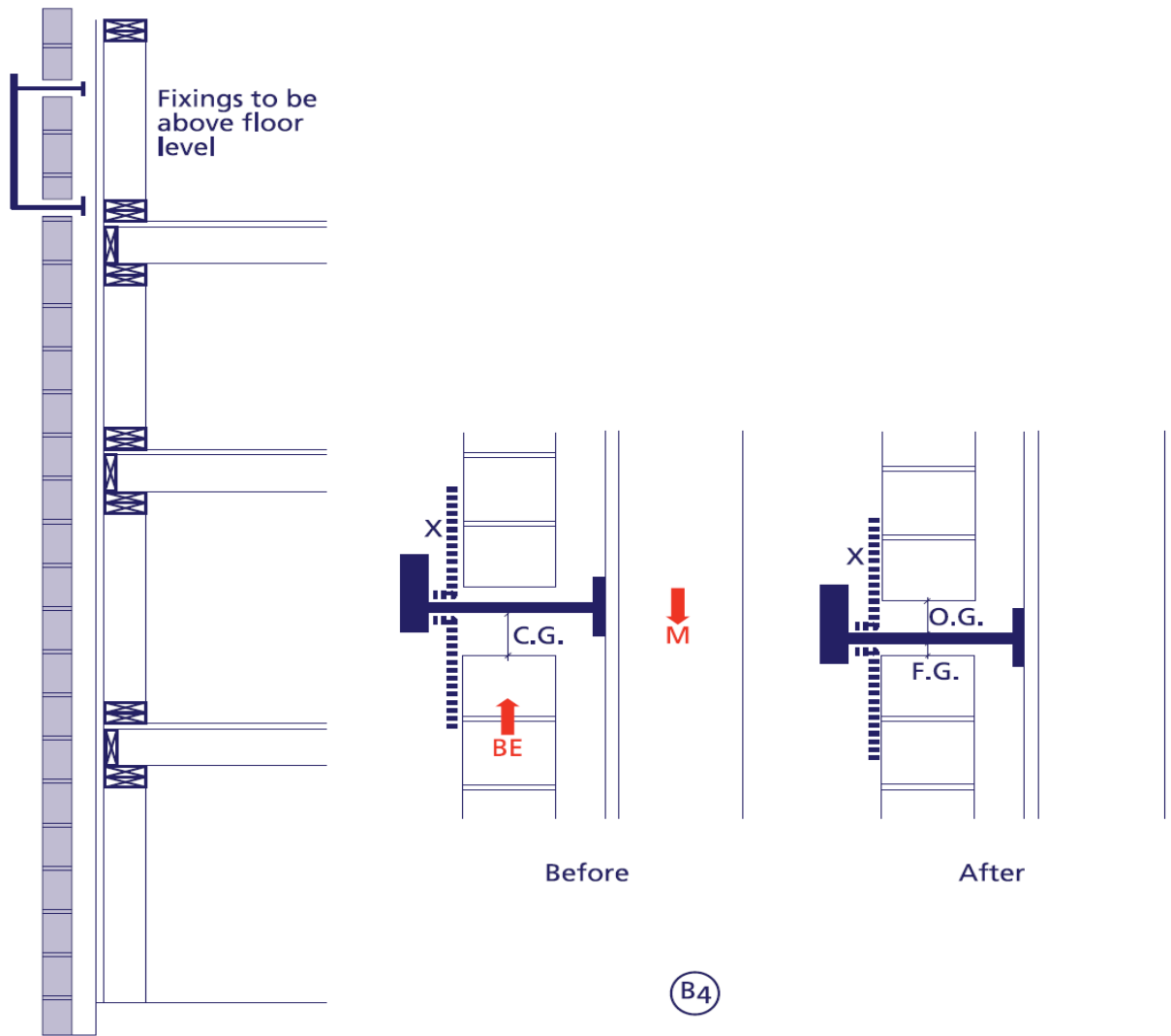
**Diagram 2.5.c – B1 detail**  
**Detail of lateral tie to timber frame**  
**showing final location of masonry to frame tie in the “after” movement stage.**



**Diagram 2.5.d**  
**Vertically free standing balcony and cladding supported to the timber frame.**  
**Balcony tied back to the timber frame for lateral support.**



**Diagram 2.5. e B 2 detail**  
**Detail of lateral tie to timber frame showing differential movement between the frame cladding and balcony structure “before” and “after” movement.**



**Diagram 2.5.e - Juliet balcony fixed to timber frame showing differential movement between masonry and balcony brackets.**

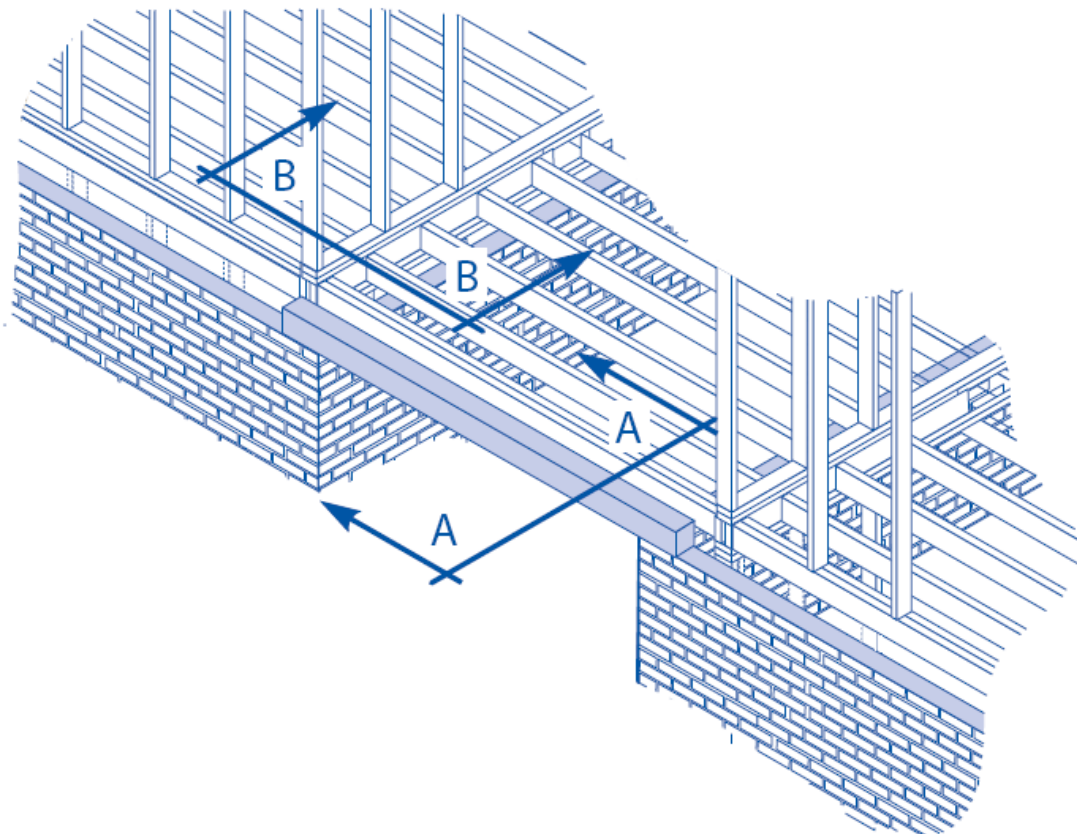
## **2.6 Joint Location      Drive-through Detail**

Building layouts sometimes require discontinuities of the timber frame structure at ground level, for example, at drive-throughs or where the frame bridges over other structures. Correct interface details are necessary to avoid damage at the point where timber frame meets the independent structure.

At drive-throughs, for example, there is often the requirement for a masonry support over the opening. It is important that the masonry lintel is supported from the adjoining masonry, not the timber frame. Where the masonry support lintel takes lateral stability from the frame via clips on the top edge it is important that the clips leave a gap above the lintel edge to allow the frame and clip to move down.

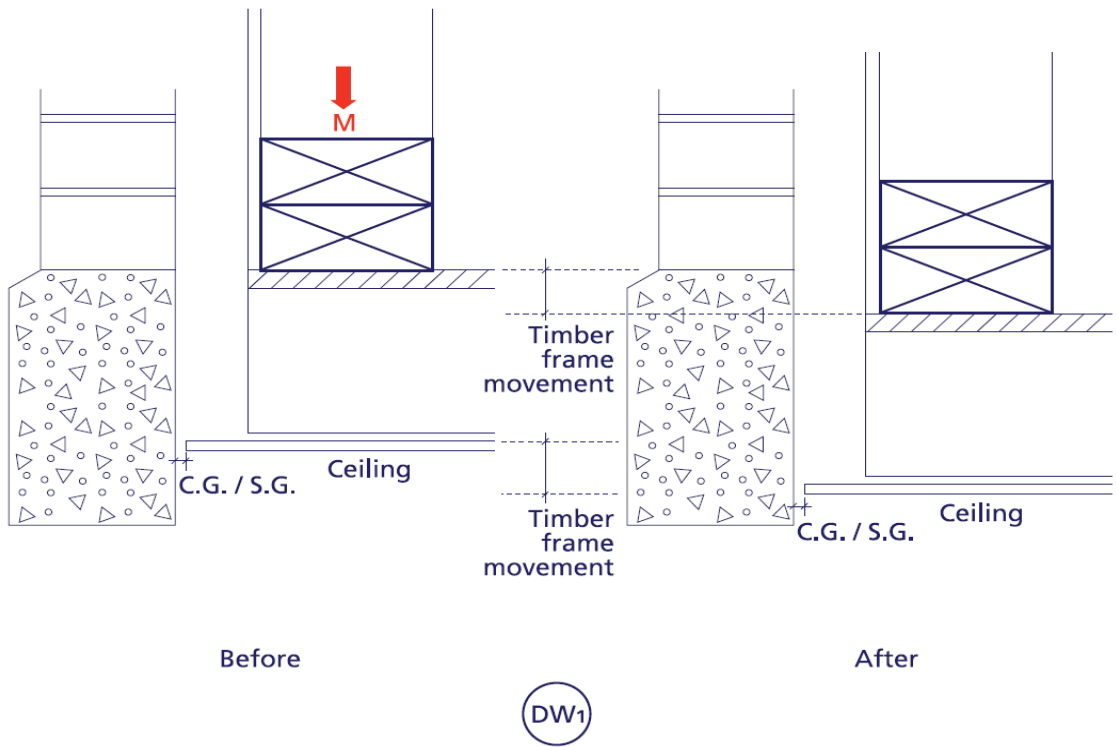
### **Avoiding Problems**

1. Ensure that any masonry built to the underside of floor above leaves a sufficient gap.
2. Ensure that any lintel clips allow sufficient gap above the top of the lintel

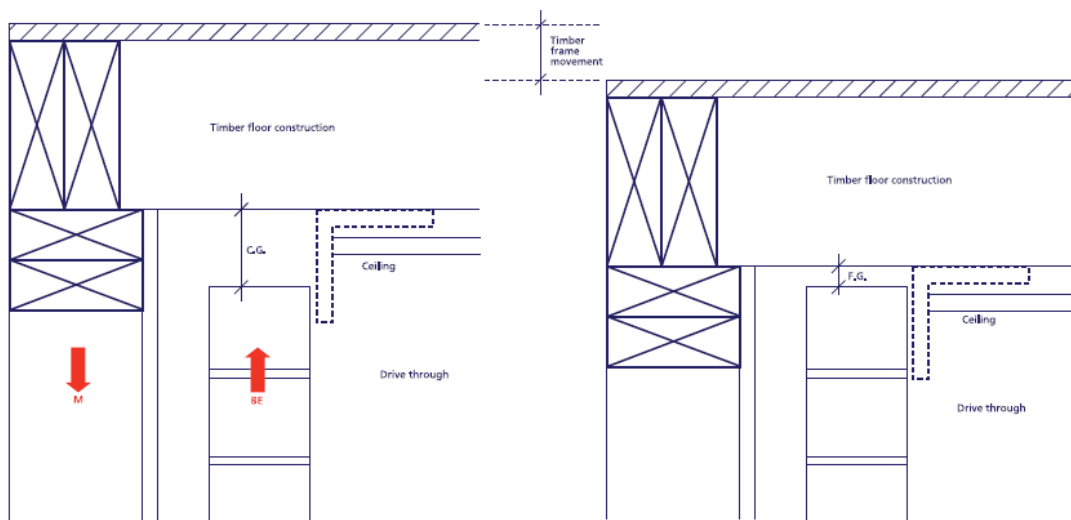


***Diagram 2.6.a***  
***Isometric view of a drive through structure***  
***with masonry returning under the timber frame***

**UKTFA - Differential Movement Guidance**



**Diagram 2.6.b – Section A- A**  
**Timber frame floor zone to drive through external lintel.**



**Diagram 2.6.c Section B-B**  
**Timber frame to the inner masonry lining to the drive through**

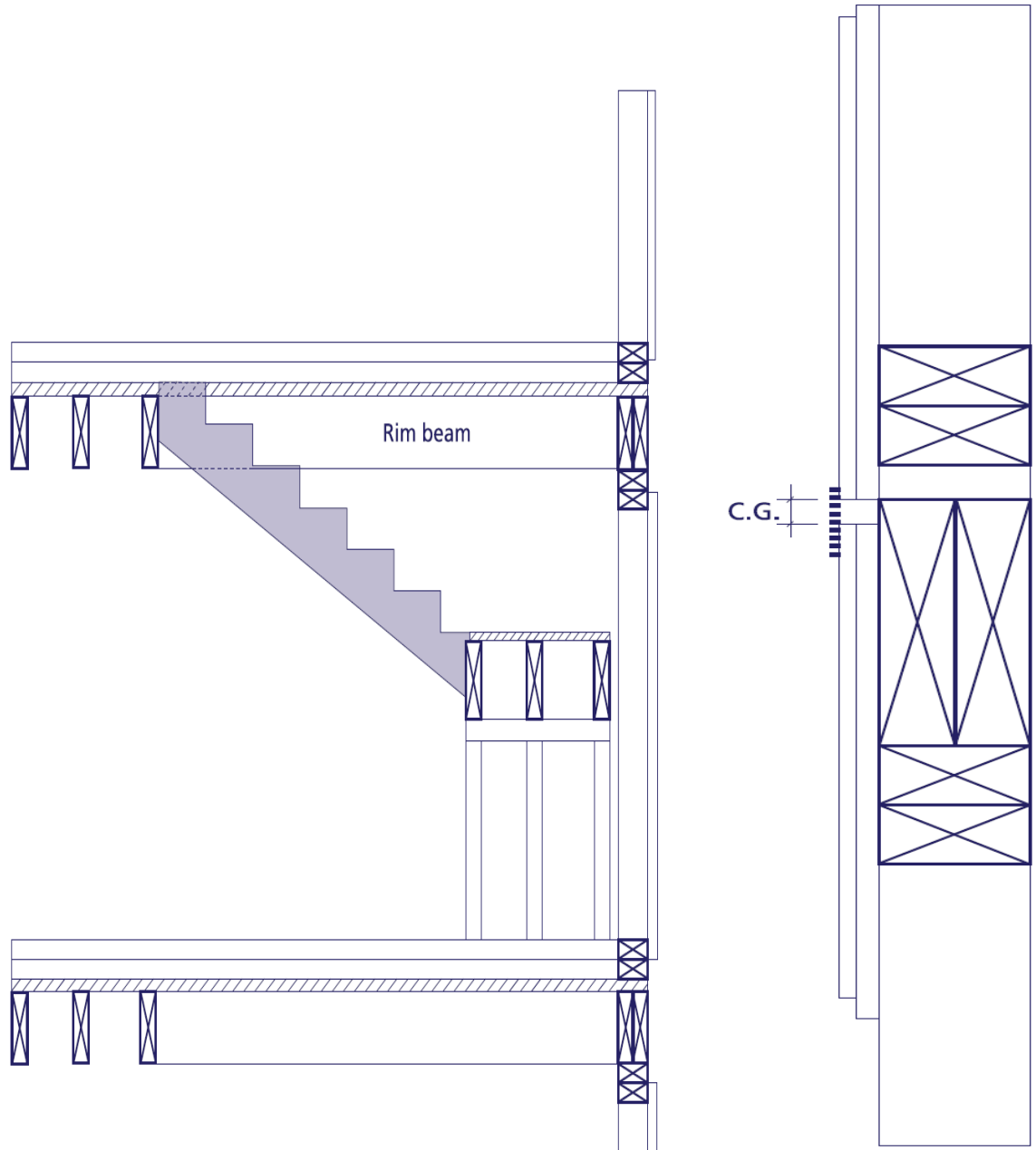
## **2.7 Joint Location – Stairs & Common Areas with Timber Frame Surround**

Timber framed stair shafts are lined with plasterboard for the full height of the building. Without any allowance for movement this lining will buckle outwards as the building shortens.

To avoid this movement joints are required at each floor level. These joints are often incorporated within an apron lining design to hide the joint. It is important that the apron lining fixing detail does not compromise the joints ability to compress.

### Avoiding Problems

1. Apron linings over a joint should be fixed on one side only (above or below, not both)
2. Use pliable sealant / intumescent that can accommodate the movement
3. Ensure that the joint exists in both layers of plasterboard, not just the outer one.
4. Ensure that all the required joints are constructed
5. Avoid full height structural newels in buildings over two storeys.
6. Avoid full height stair newels that bridge floor to floor zones and thereby stop vertical movement across the floor zone

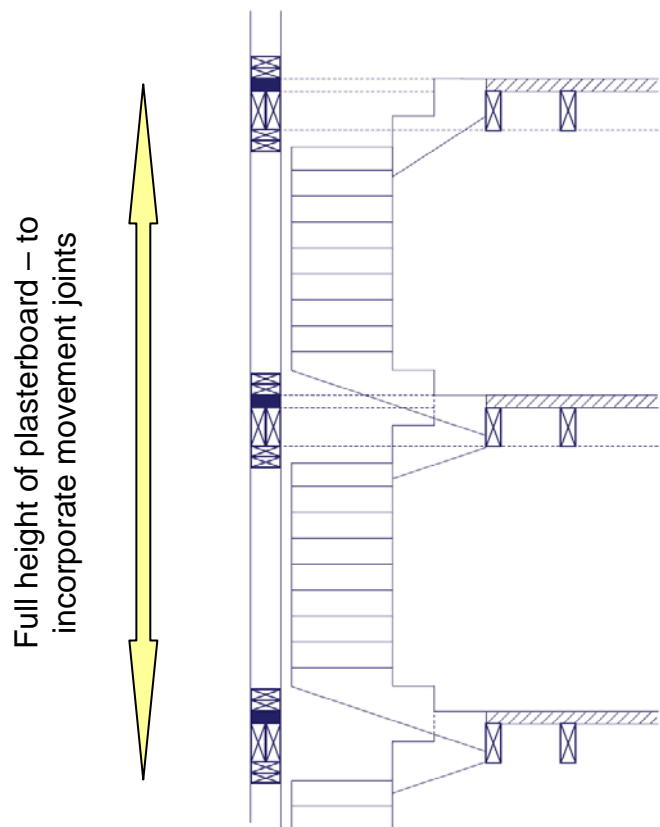


**A**

**Diagram 2.7a**

**A - Cross section through stair zone showing the areas where cross grain timber cause shortening**

**B- Detail cross section through the plasterboard joint ( typically for buildings over 2 storeys in height)**



**Diagram 2.7b**  
**Cross section through stair zone showing where plasterboard can be subject to stresses.**

## **2.8 Joint Location – Concrete and Masonry Stairs / Common Areas with Timber Frame Surround**

In Scotland the building standards do not currently allow stair shafts, common areas or lift shafts to be constructed in timber. This means that in Scotland apartment buildings have masonry and concrete common areas as cores surrounded by timber frame apartments. The interface between the perimeter of the core and the surrounding apartments is a compartment wall consisting of two separate leaves, one of masonry and one of timber frame, with a cavity between. This cavity acts as the movement joint between the two areas.

Apartment entrance doors and any junction with the surrounding roof needs appropriate detailing to avoid damage.

Apartment entrance doors are located over the junction between the timber and masonry sections but only fixed to one side. The joint is hidden behind the architrave. To allow for the shortening it is common practice to set the timber finished floor 6mm above the common area floor and place a small fillet against the step to provide a smooth transition. This fillet is removed following the completion of the shortening process. This is normally a maximum of two years although most movement occurs within a year of occupation.

The differential movement is also reflected at roof level. Roofs supported on the timber frame will move differentially to roofs supported by the masonry core. It is therefore important to detail the junction between the two with care. It is not uncommon for timber frame roof to be designed and detailed so that it clear spans over the masonry core without using the core for support. In these instances it is important to consider the preservation of fire integrity and allow sufficient clearance above the masonry core to allow the roof members to move down with the frame without fouling on the masonry<sup>5</sup>.

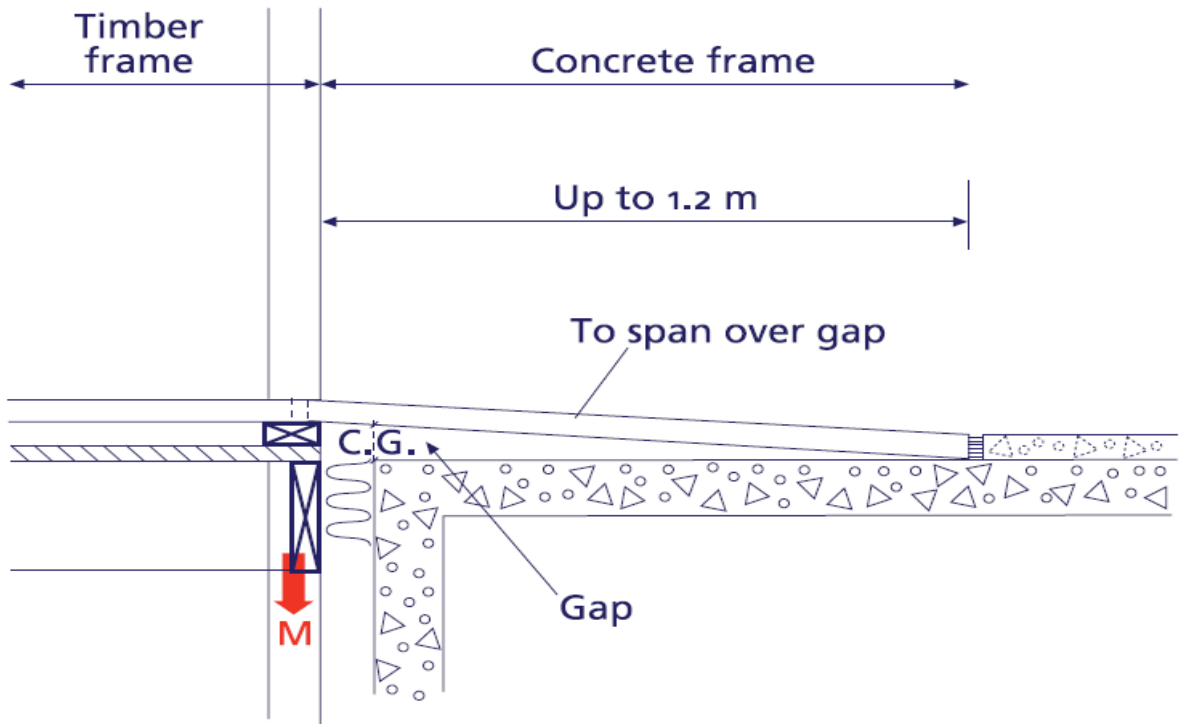
### **Avoiding Problems**

1. Use a sealing system that can cope with the movement<sup>6</sup>.
2. Ensure joints are not compromised by mortar intrusion
3. Ensure that entrance door linings are only fixed to one leaf allowing movement with the other leaf.

---

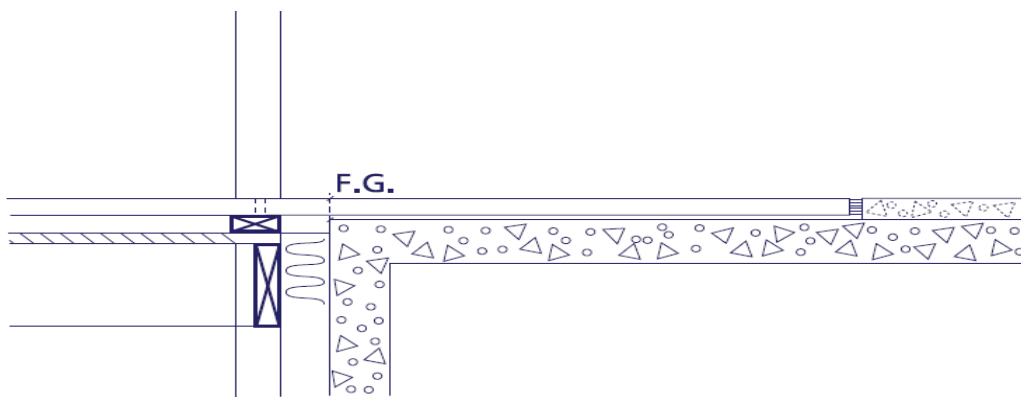
<sup>5</sup> For lift shafts refer to the lift shaft section

<sup>6</sup> Note the UKTFA does not recommend the use of silicone sealants in this situation



At construction

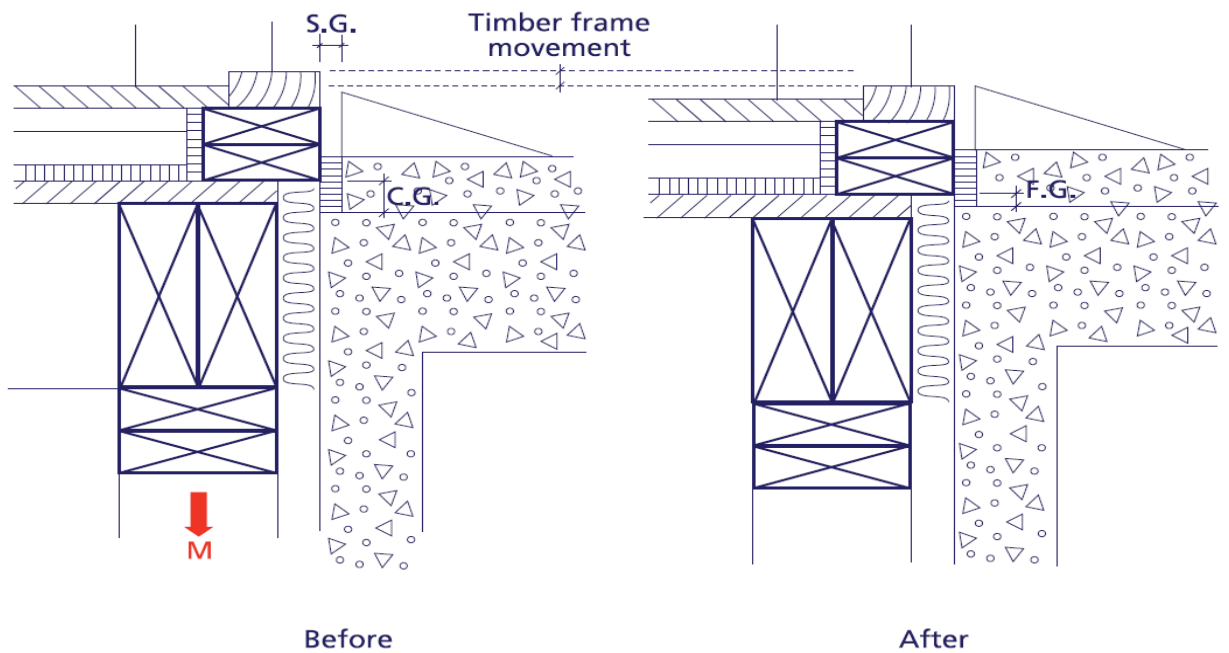
**Diagram – 2.8 a – Timber frame junction with concrete/ masonry stair core as built showing transition structural deck to span across the two structural types.**



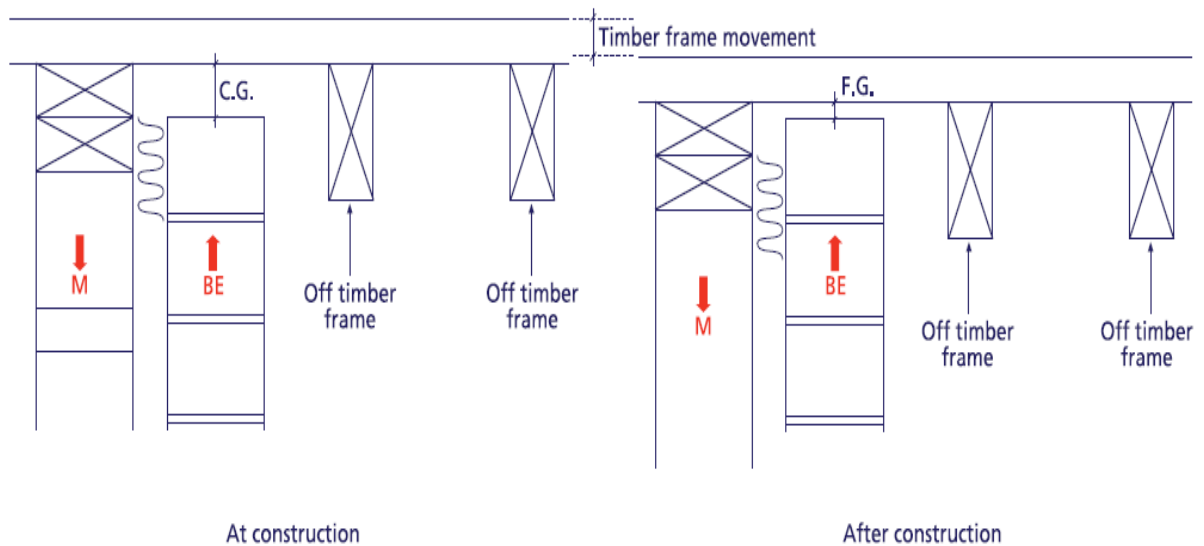
After movement

TC2

**Diagram – 2.8 b – Timber frame junction with concrete/ masonry stair core after movement showing transition structural deck.**



**Diagram – 2.8 c – Timber frame junction with concrete/ masonry stair core before and after movement showing transition gap taken up by door threshold**



**Diagram – 2.8 d – Timber frame roof junction with concrete/ masonry stair core – before and after movement..**

## **2.9 Joint Location – Lift shafts**

Lift shafts will commonly consist of;

- a) A masonry or concrete shaft surrounded by timber frame with a small cavity.
- b) A lift manufacturer's steel support shaft with lateral supports at floor level surrounded by timber frame.
- c) A set of lift car guides bolted back to a steel support laterally restrained by the timber frame within a timber framed shaft.

In each of these scenarios the structure carrying the lift car will not shorten with the frame. It is therefore essential to surround the shaft with timber frame including a cavity to act as a movement joint.

The outer lift access doors are fixed to the timber frame. At each maintenance visit the lift engineer will recalibrate the lift to account for any differential movement across the lift threshold.

It is particularly important that the top of the masonry / steel lift shaft does not become loaded by the shortening timber frame. Movement allowances need to be made in this area. (Refer to diagram 2.8d for example of detail.)

### **Avoiding Problems**

1. Ensure outer lift access doors are only fixed to the timber frame wall.
2. Provide sufficient movement allowance between any steel support and the timber frame. Where this detail consists of a slotted hole arrangement it is vital that the restraining bolts are fixed at the top of the slot to allow movement down with the frame. Consideration also needs to be given to methods of reducing friction loads that may frustrate the joint performance.
3. Provide sufficient allowance at the junction between the top of the shaft and independent roof structure to allow frame shortening to occur.

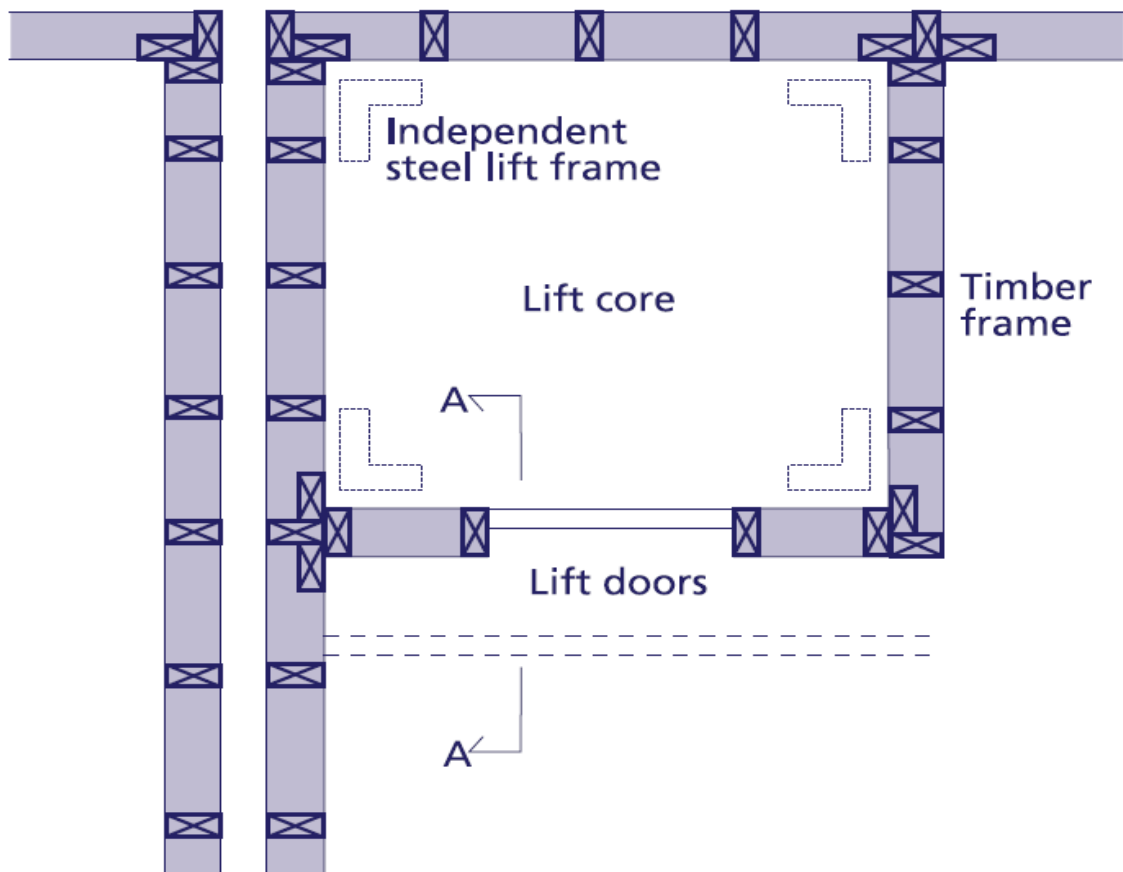


Diagram – 2.9a – Timber frame lift shaft – diagrammatic plan.

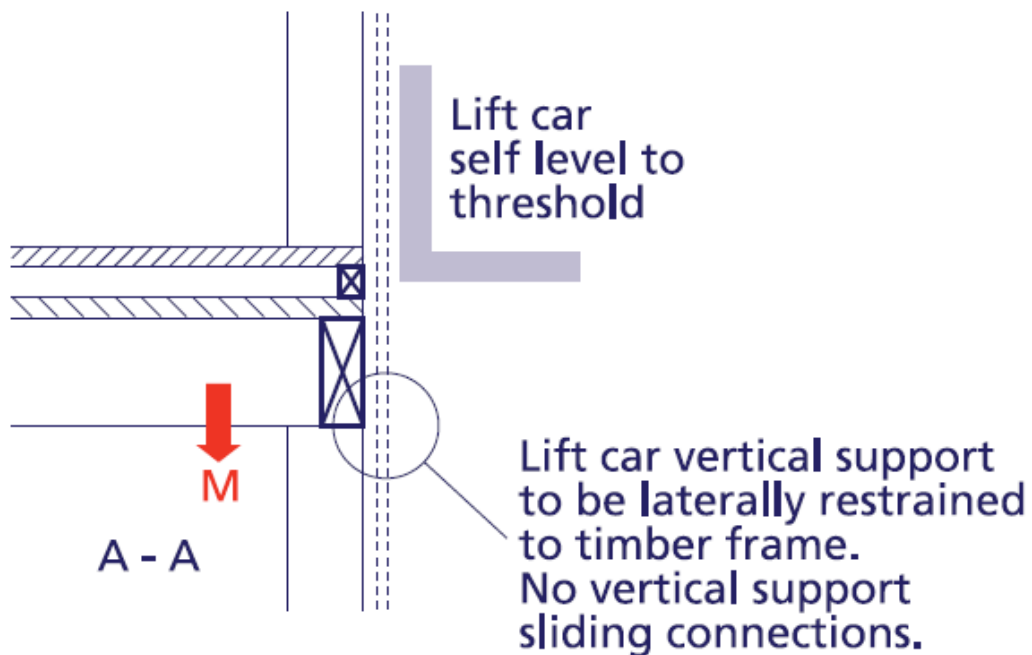
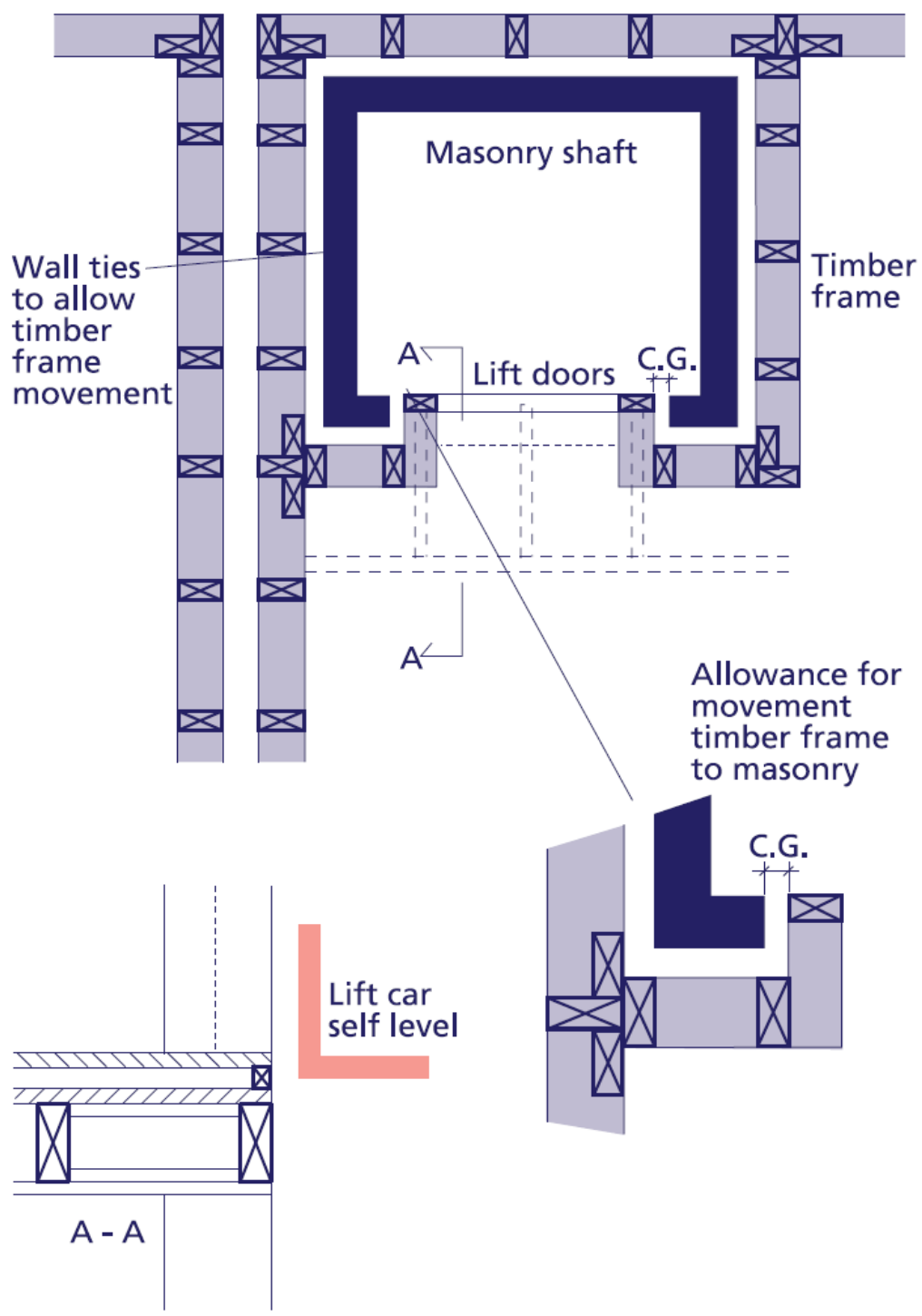


Diagram – 2.9b – Timber frame lift shaft to car frame junction it is essential that there is a sliding joint between the lift frame and the timber frame



**Diagram – 2.9b – Masonry lift shaft with surrounding timber frame– it is essential that there is a joint to allow differential movement between the timber frame and masonry.**

## **2.10 Joint Location – Services**

It is not unusual for services to rise vertically for the full height of the building within a service shaft. Typical examples are soil vent pipes, cable trays and dry risers. These services must take account of the building shortening otherwise they will be damaged.

### *Soil Vent Pipes*

Soil vent pipes need to accommodate the movement in the surrounding frame. Rigid bracket supports should be avoided. In addition minimum waste pipe falls need to be increased to account for frame shrinkage. This is because the SVP will remain static (Movement being catered for by the brackets) whilst the appliance moves downward with the building therefore decreasing the originally constructed fall.

### *Cable Risers*

Cable trays should not be continuous across the floor zone and where appropriate cables should be bent to allow the shortening in the cable run to be catered for.

### *Wet & Dry Risers*

Rigid connections, for example within cast iron piping, are to be avoided. Any supporting trays or brackets must avoid loading pipework as the frame shortens. “Compression loops” may be required to control shortening in vertical runs.

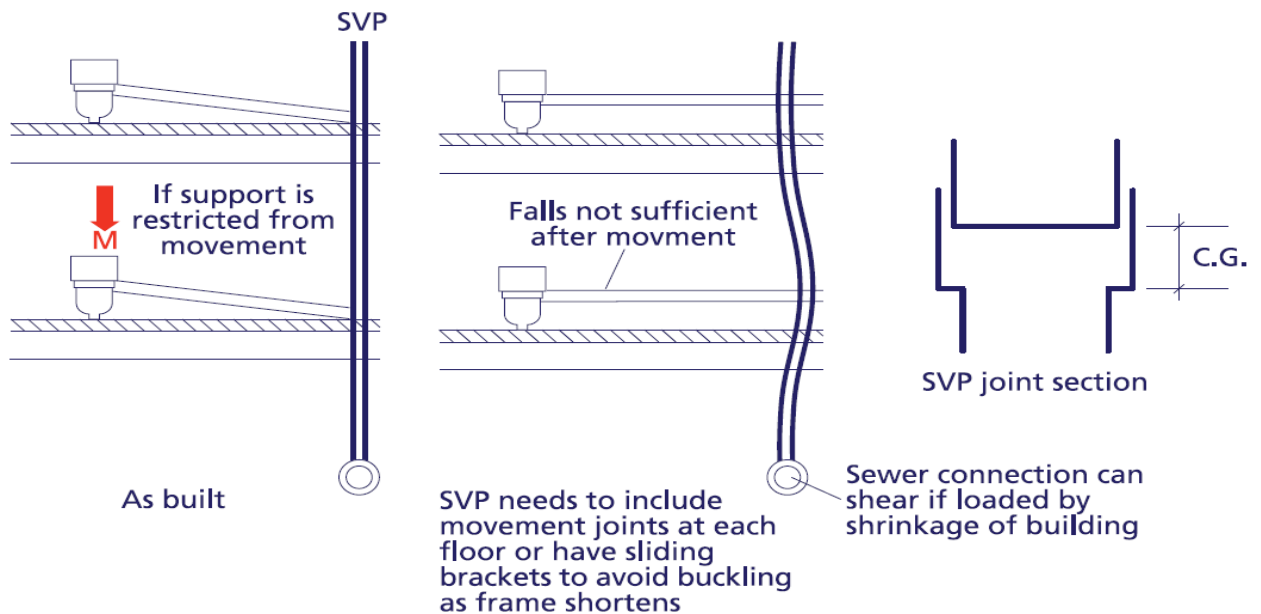
### *Gas Distribution*

Similarly, attention is particularly drawn to services crossing from masonry built common areas into apartments within Scotland. Whilst the cavity within the party wall will move it is of particular importance that the service entry can also cope with the movement whilst preserving fire integrity.

Similar consideration is required where services pass through external cladding. For example, with masonry cladding it is important that a flexible junction is used across the cavity to avoid shearing the grille from the end of a ventilation duct.

Avoiding Problems

1. Provide additional falls for soil and waste pipe branches
2. Avoid rigid support brackets being used on soil vent pipes. Note: Soil vent pipes have sheared off at the base with this fault.
3. Avoid rigid connection on wet and dry risers and design in movement details.
4. Provide gaps in cable trays to provide movement at floor levels.



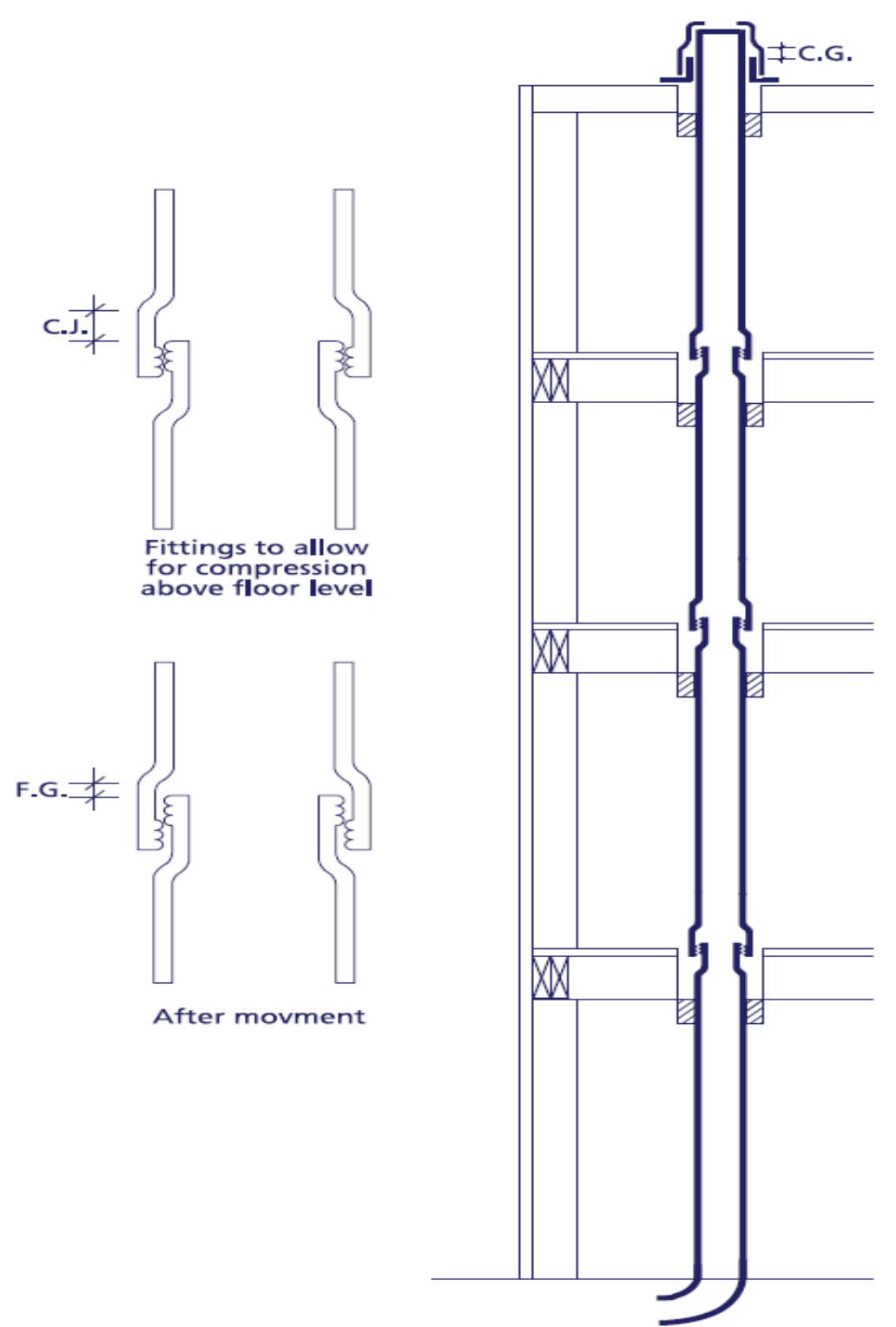
What can go wrong if no allowance for movement is provided

**Diagram – 2.10a – Diagrammatic view of the soil pipes**

incorrectly positioned at construction stage vertical pipes buckle and falls reduce as shortening occurs.

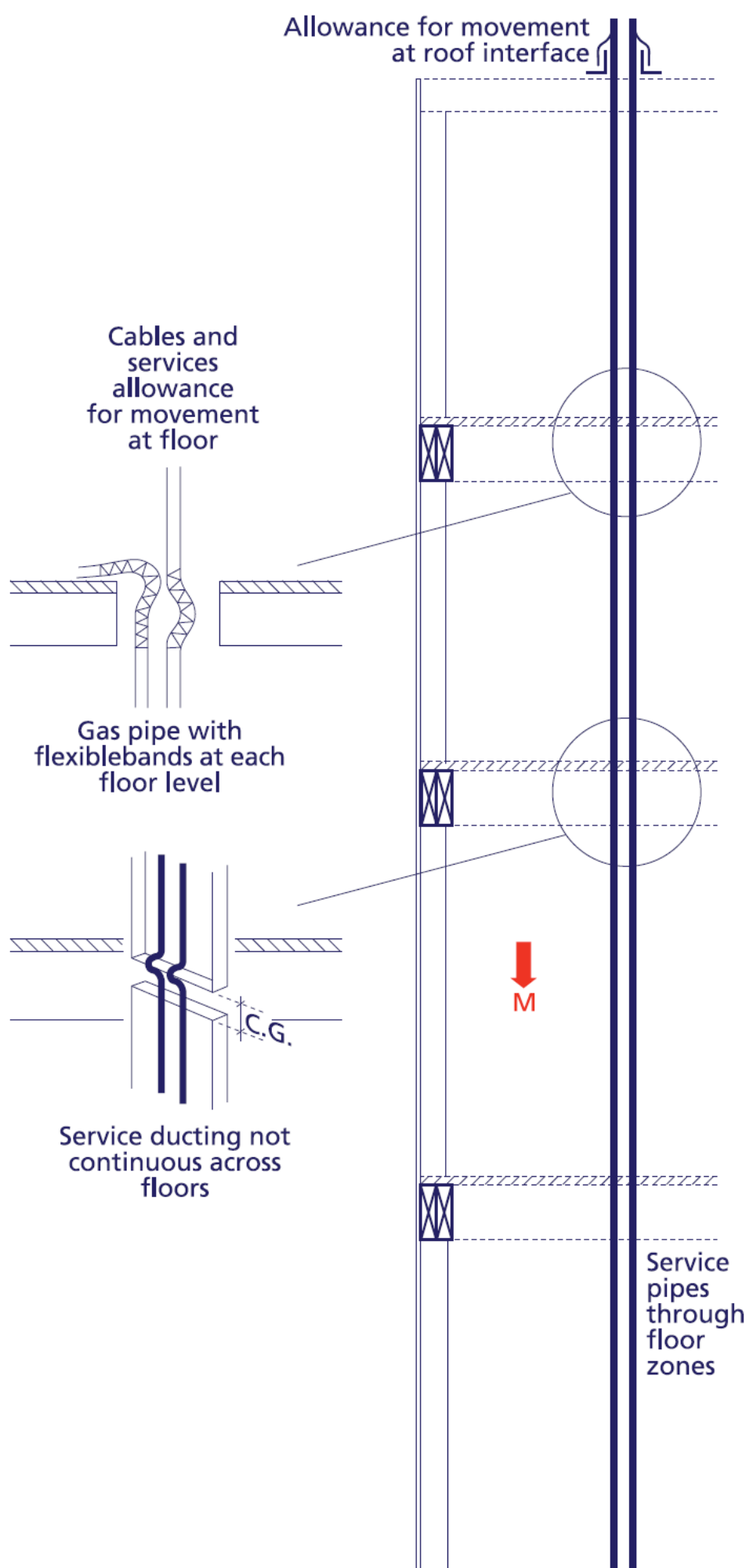
The vertical pipes should have allowance for movement in the pipe joints

(Refer Diagram 2.10 b)

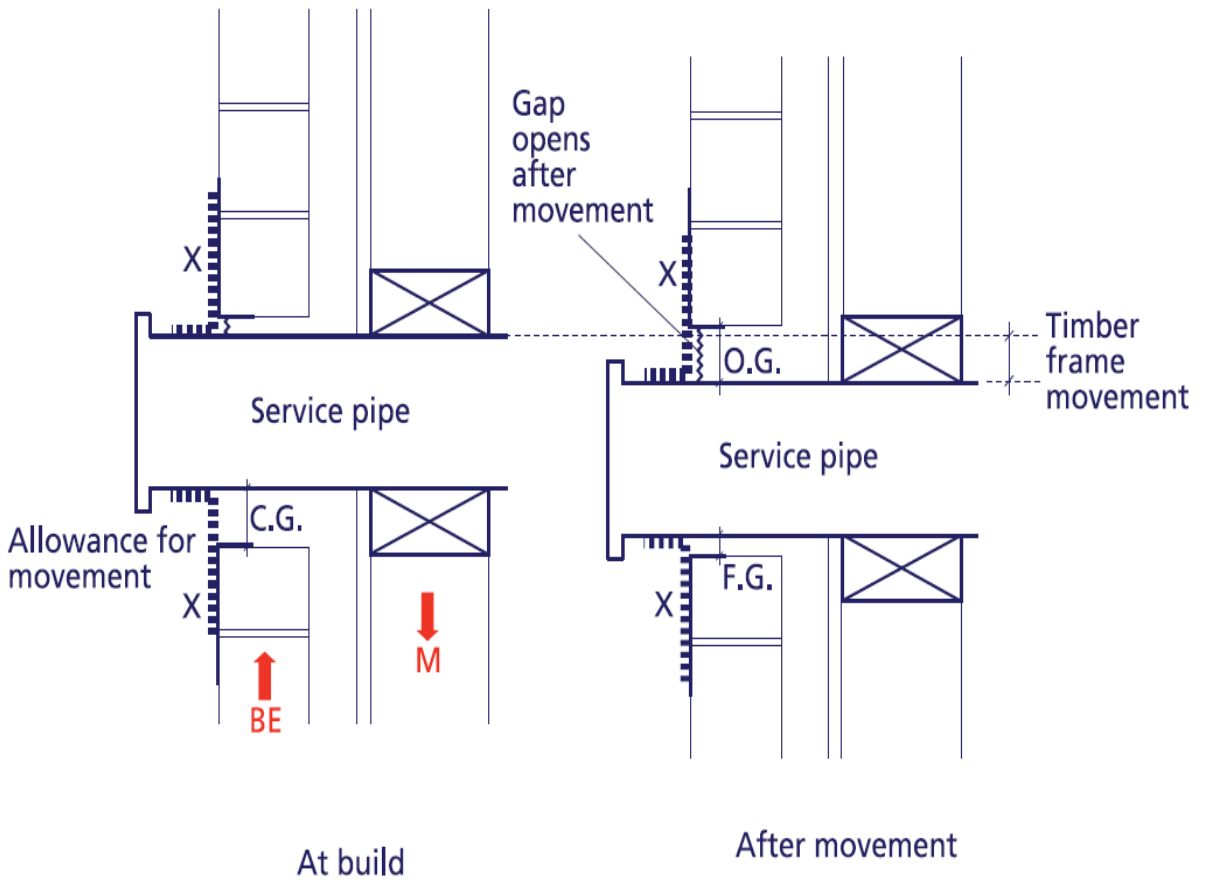


**Diagram – 2.10b – Diagrammatic view of vertical pipes with allowance for movement in the pipe joints.**

**UKTFA - Differential Movement Guidance**



**Diagram – 2.10c – Diagrammatic view of Mechanical and Electrical service ducts showing allowance for vertical movement.**



**Diagram – 2.10d – Service pipes at junction with masonry cladding showing allowance for vertical movement.**

## **2.11 Joint Location – Chimneys and Masonry fireplaces**

Typical Masonry chimneys cannot be supported by timber frame. There are three common solutions for the provision of chimney stacks.

### *“False” chimneys*

Provided for aesthetic purposes these are commonly prefabricated “lightweight” units which can be supported by roof trusses or the timber frame. Where these units only interface with roof coverings no differential movement occurs.

Chimneys located on gable ends must be entirely supported by the timber frame and a movement joint provided between the external masonry and the dummy chimney. For this reason it is usually a better solution to inset the chimney slightly to avoid this interface.

### *“Hollow block” flues*

More commonly used within masonry housing it is possible to use these types of flue in timber frame. The timber frame is detailed with openings in the external wall which allow the blocks to be built in line with the wall. It is essential that all interfaces between the blockwork and the frame are built to allow the frame to shrink independently of the flue blocks. Particular care should be given to the fixing of internal finishes as these can distort when fixed directly to both frame and block.

### *Masonry chimneys*

An alternative is to construct the flue / chimney entirely within the external masonry thereby preserving the cavity and the ability of the frame to move independently.

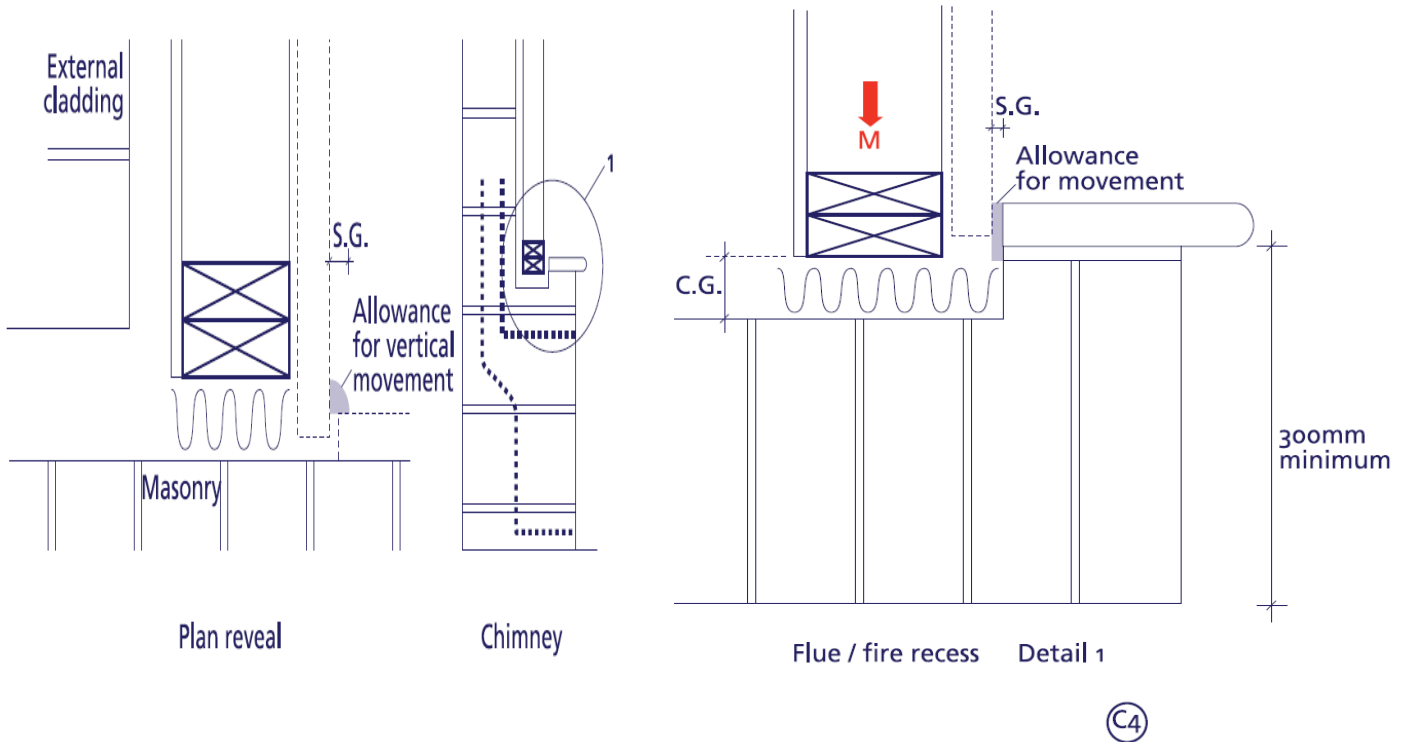
### *Avoiding Problems*

1. Ensure that any interface between blocks / masonry and the timber frame allow for movement.
2. Ensure joints are not compromised by mortar intrusion
3. Use a sealing system that can cope with the movement<sup>7</sup>

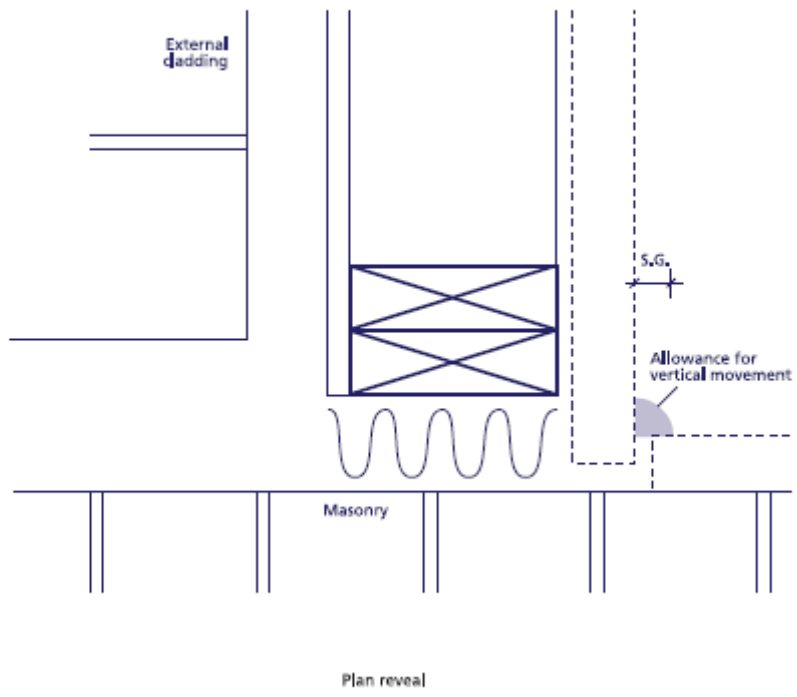
---

<sup>7</sup> Note the UKTFA does not recommend the use of silicone sealants in this situation

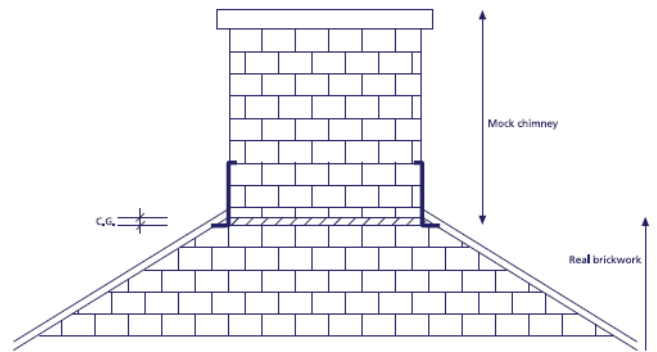
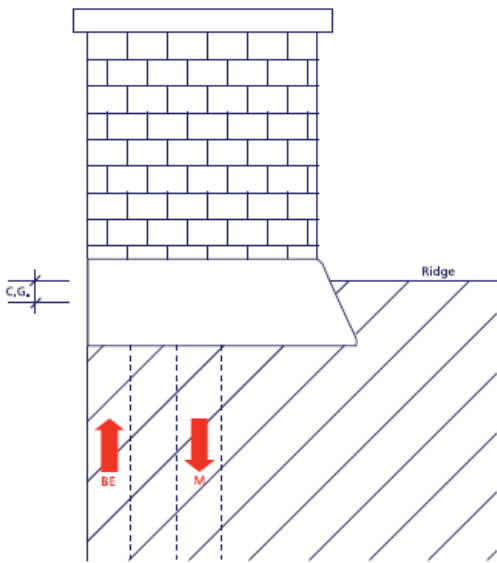
**UKTFA - Differential Movement Guidance**



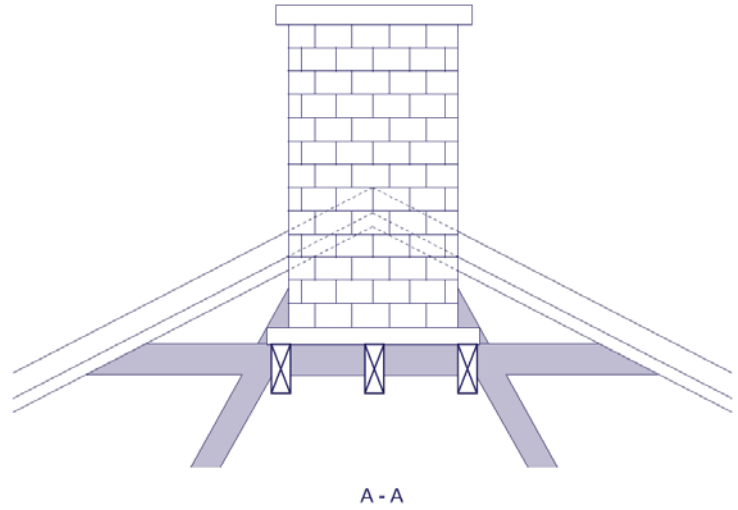
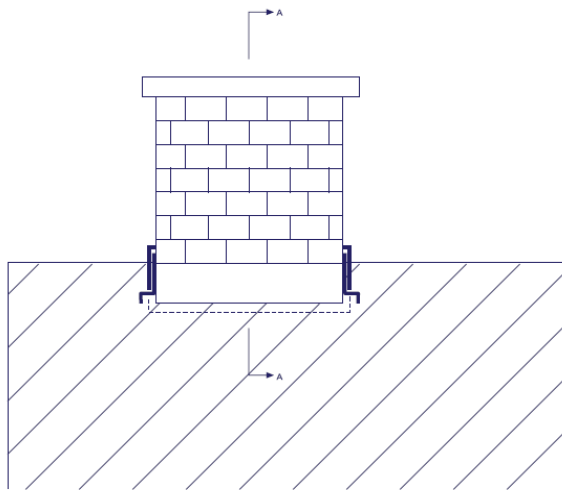
**Diagram – 2.11 a—detail of the timber frame and masonry flue showing the joint for vertical movement.**



**Diagram – 2.11 b-Plan detail of the timber frame and masonry flue showing the joint for vertical movement.**



**Diagram – 2.11 c– consideration for the differential movement of lightweight chimneys supported off the timber frame.**



**Diagram – 2.11 d alternative support of lightweight chimney on truss roof.**

## **2.12 Joint Location – Existing Building Extensions**

Where timber framed extensions are built onto an existing masonry building or an older timber framed there needs to be a movement joint provided at the junction.

The reason for the requirement against an existing timber framed building is that the new frame will move differentially against the existing frame that has completed the shortening cycle.

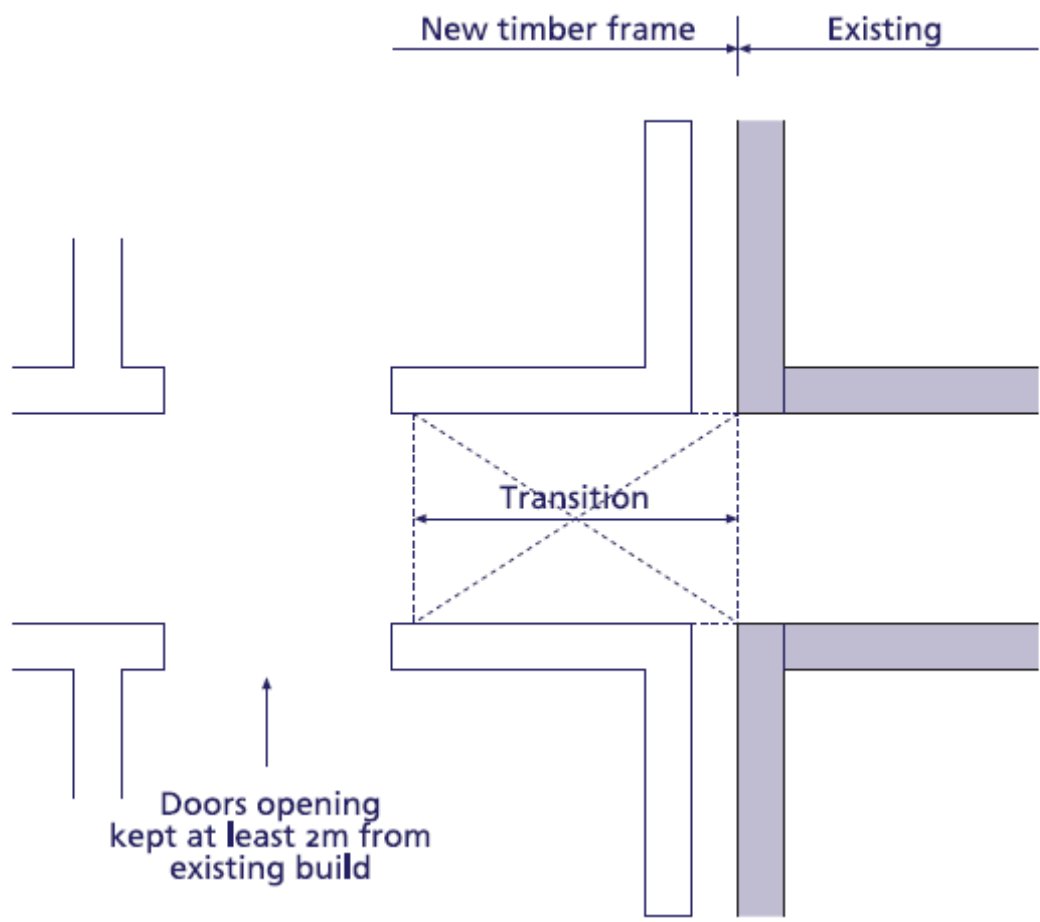
Any link at floor level between the two buildings should be designed as a “drawbridge” that will allow rotation at each end without damage. If the link is not capable of being detailed as an independent structure then the junction needs to be made flexible.

Hotels are a common example where a central corridor has rooms on either side. The new building floor level can be preset above the existing to account for the expected shortening. To avoid a step at floor level the corridor joists are turned round to span from the new build ONTO the existing structure over a distance of 2-3 metres. This means that the floor can rotate to allow the movement to take place without compromising the function of the building. To allow this detail to be implemented it is important that room access doors are kept clear of this area to avoid a secondary step at this junction.

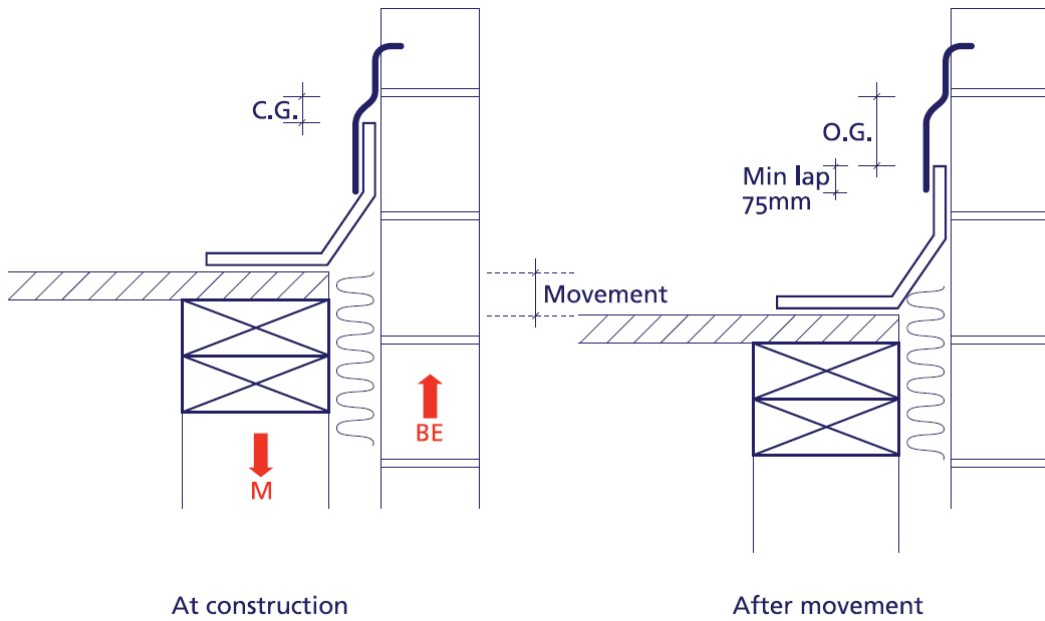
Additionally it is not good practice to try and line up roofs between new and old. The subsequent movement will show at eaves and ridge levels producing unsightly roof lines.

### **Avoiding Problems**

1. Provide a timber frame end wall and cavity at the junction with the existing building to facilitate movement.
2. Design roofs with a break or parapet to hide any differential movement and don't make eaves lines continuous across the joint
3. Use flashings to preserve weather tightness
4. Detail the structure to allow flexible links between the two buildings



**Diagram – 2.12 a Junction of existing structure and new timber frame.**



**Diagram 2.12b** *Differential movement between timber frame and masonry/adjacent structure*